

1

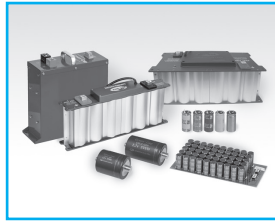

**Green-Cap
(ELECTRIC DOUBLE LAYER
CAPACITORS)**

21

2

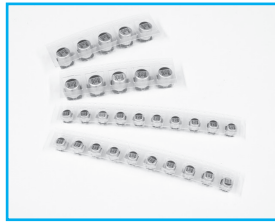

**CONDUCTIVE POLYMER
HYBRID ALUMINUM ELECTROLYTIC
CAPACITORS**

37

3

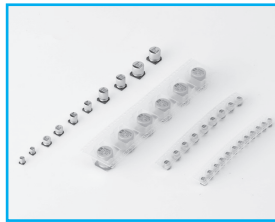

**SURFACE MOUNT
ALUMINUM ELECTROLYTIC
CAPACITORS**

53

4



**MINIATURE
ALUMINUM ELECTROLYTIC
CAPACITORS**

81

5



**LARGE
ALUMINUM ELECTROLYTIC
CAPACITORS**

167

SERIES CHART

Green-Cap (ELECTRIC DOUBLE LAYER CAPACITORS)

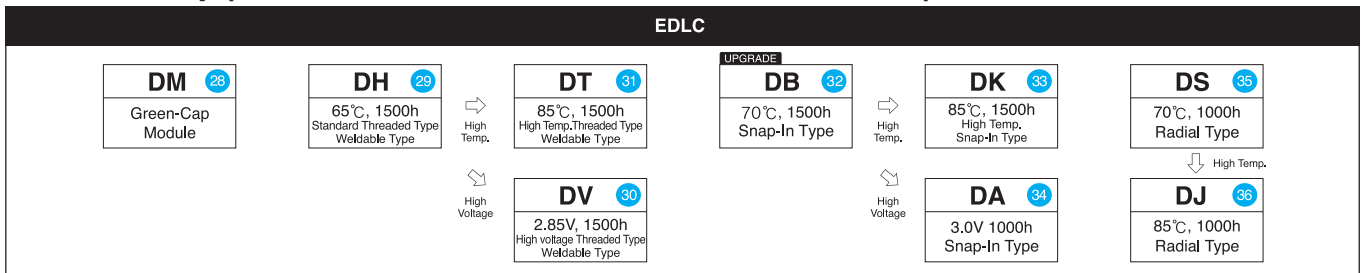

Conductive polymer hybrid aluminum electrolytic capacitors

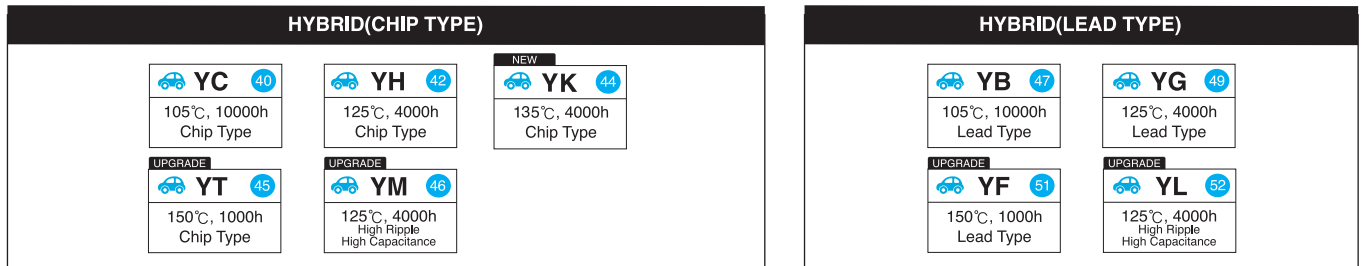

ALUMINUM ELECTROLYTIC CAPACITORS

CHIP TYPES

: AEC-Q200 compliant

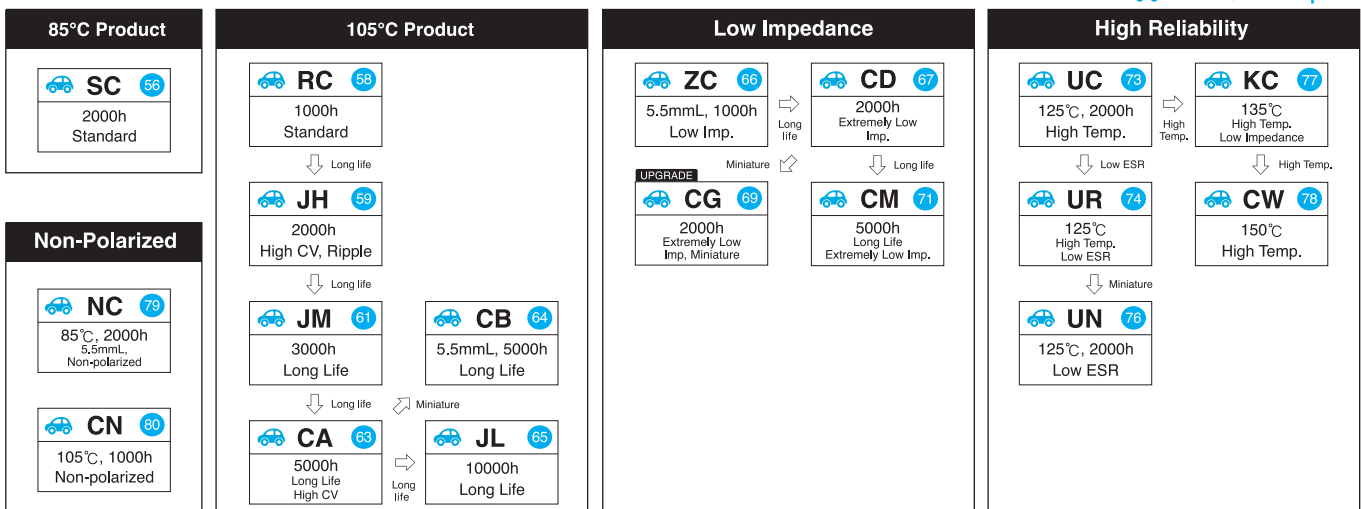

MINIATURE RADIAL LEAD TYPES

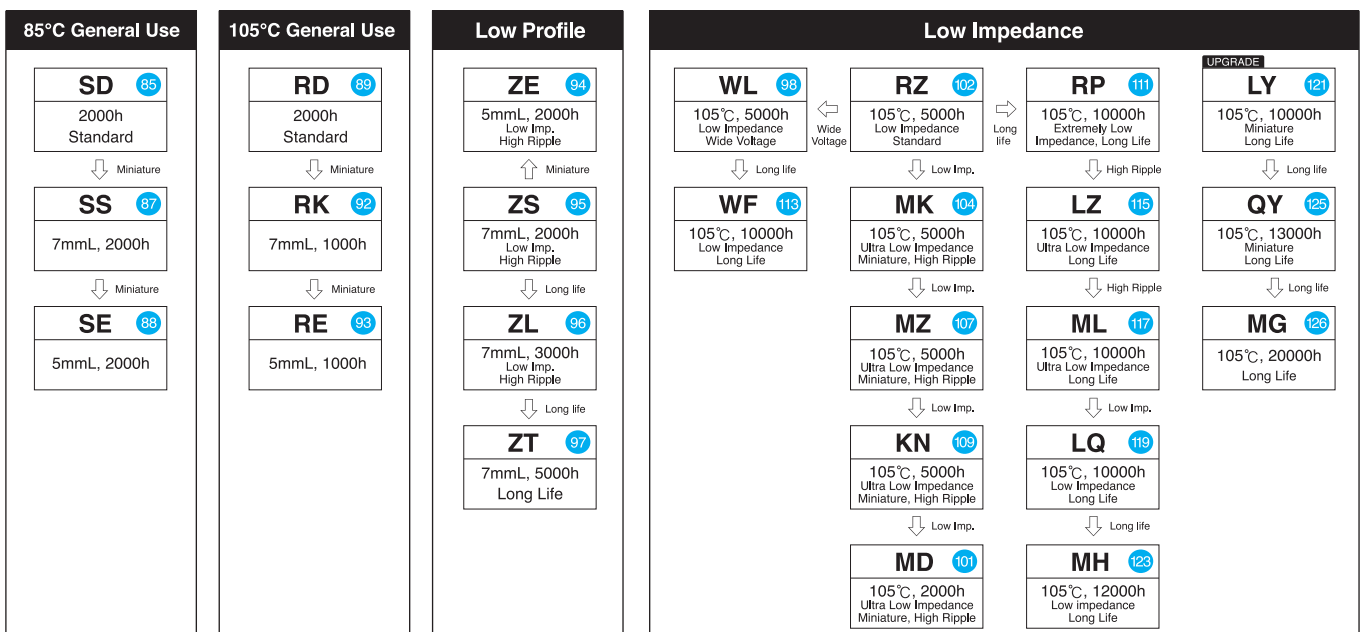

ALUMINUM ELECTROLYTIC CAPACITORS

MINIATURE RADIAL LEAD TYPES

PSU, SMPS, Adapter		High Temperature		Special Applications	
KS 127 85°C, 8000h Ultra Low Impedance Miniature, High Ripple	UPGRADE BN 141 105°C, 12000h Long Life -40°C Assurance High Ripple	RB 146 125°C, 2000h High Temperature	WP 149 125°C, 5000h High Temp.	UPGRADE MW 156 105°C, 5000h High Ripple	UPGRADE VP 157 135°C, 3000h For LED High Temp.
↓ Long Life	↑ Miniature	↓ High Ripple Long Life	↑ Low ESR.	↓ High Temp.	
KA 129 105°C, 3000h	SB 128 85°C, 10000h High Ripple	KJ 139 105°C, 12000h Long Life -40°C Assurance High Ripple	WT 151 125°C, 5000h High temp. Low Imp. Long Life	VQ 158 150°C, 1000h High Temperature	
↓ Long Life	↓ High Temp.	↑ High Ripple	→ High Ripple		
RH 131 105°C, 5000h For PSU	BL 135 105°C, 10000h For PSU Long Life	MT 137 105°C, 12000h For PSU Long Life, High Ripple	BK 155 125°C, 5000h High Temp.		
↓ High Ripple	↔ Long Life	↓ Long Life	↓ High Temp.		
BH 133 105°C, 5000h For PSU High Ripple		MP 142 105°C, 15000h For PSU Long Life	LJ 153 130°C, 4000h For LED High Temp.		
↓ High Ripple		↓ Long Life			
KU 134 105°C, 5000h		MJ 144 105°C, 20000h For PSU Extremely Long Life			
			Non-Polarized		
				NP 161 85°C, 2000h Standard	NE 164 5mmL, 1000h
					↑ Miniature
				RN 165 105°C, 1000h Standard	↔ Miniature NS 163 7mmL, 2 000h

LARGE TYPES

Snap-in Terminal			Screw, Lug Terminal			Special Application	
HC 171 85°C, 2000h Standard	HE 180 105°C, 2000h Standard	JK 183 105°C, 2000h Printer system	GT 201 85°C, 2000h For Inverter	GY 204 85°C, 2000h High Ripple	CU 205 105°C, 2000h Wide Temp.	NEW AL,AK 218 85°C For Air- conditioning system	AY 219 105°C For Air- conditioning system
↓ Long Life	↓ Long Life	↔ High Ripple	↓ Long Life	↔ High Ripple	↓ Long Life	↔ High Temp.	
HJ 174 85°C, 3000h Miniature	HK 184 105°C, 3000h Long Life	HG 187 105°C, 3000h High Ripple Wide Temp.	GF 208 85°C, 5000h For Inverter	GR 210 85°C, 5000h High Ripple	EV 213 105°C, 5000h Long Life		
↓ Long Life	↓ Long Life	↔ High Ripple	↓ Long Life	↔ High Ripple	↓ Long Life		
HF 177 85°C, 5000h Long Life	UPGRADE HL 190 105°C, 5000h Long Life	UPGRADE KG 188 105°C, 3000h High Ripple Wide Temp.	GL 212 85°C, 20000h Long Life		EY 214 105°C, 7000h Long Life	LW,SW 215 85°C Welding Machine	
↓ Long Life	↓ Long Life	↓ High Ripple					
JR 179 85°C, 10000h Long Life	HY 193 105°C, 7000h Long Life	HH 189 105°C, 3000h Surge Voltage	LM 199 85°C, 2000h Lug Terminal			AM 216 85°C, 2000h For Audio	
	↓ Long Life						
HB 197 125°C, 1000h High Temp.	JY 195 105°C, 10000h Long Life	NEW JZ 196 105°C, 20000h Long Life				DF 217 For Photo Flash	
	↔ Long Life	↔ Long Life					

CONTENTS

1 Green-Cap (Electric Double Layer Capacitors)

★ New series
☆ Upgrade series

Series	Features	Operating Temperature Range (°C)	Voltage Range (VDC)	Capacitance Range (F)	Load Life Time (hours)	Page
DM	Green-Cap Module	Green-Cap modules are supplied on custom-made basis.				28
DH	Axial type, high power density	-40 ~ 65	2.7	1200 ~ 3400	1500	29
DV	Axial type, high power density, high voltage	-40 ~ 65	2.85, 3.0	1200 ~ 3400	1500	30
DT	Axial type, high power density, high temp.	-40 ~ 85	2.5	1200 ~ 3000	1500	31
DB ☆	Snap-in type, standard series	-25(-40) ~ 70(65)	2.5, 2.7	100 ~ 600	2000	32
DK	Snap-in type, high temp.	-40 ~ 85	2.7	100 ~ 400	1500	33
DA	Snap-in type, high voltage	-40 ~ 65	3.0	100 ~ 480	1500	34
DS	Lead type	-30(-40) ~ 70(65)	2.5, 2.7, 3.0	3 ~ 100	1000	35
DJ	Lead type, high temp.	-40 ~ 85	2.5	3 ~ 50	1000	36

2 Conductive Polymer Hybrid Aluminum Electrolytic Capacitors

Series	Features	Operating Temperature Range (°C)	Voltage Range (VDC)	Capacitance Range (μF)	Load Life Time (hours)	Page	
SMD	YC	Chip type, HYBRID long life	-55 ~ 105	16 ~ 100	10 ~ 560	10000	40
	YH	Chip type, HYBRID high temp.	-55 ~ 125	16 ~ 100	10 ~ 560	4000	42
	YK ★	Chip type, HYBRID high temp.	-55 ~ 135	25 ~ 63	33 ~ 470	4000	44
	YT ☆	Chip type, HYBRID ultra high temp.	-55 ~ 150	25 ~ 63	15 ~ 270	1000	45
	YM ☆	Chip type, HYBRID ultra high temp. high ripple	-55 ~ 125	25 ~ 63	47 ~ 680	4000	46
LEAD	YB	Lead type, HYBRID long life	-55 ~ 105	16 ~ 100	10 ~ 560	10000	47
	YG	Lead type, HYBRID high temp.	-55 ~ 125	16 ~ 100	10 ~ 560	4000	49
	YF ☆	Lead type, HYBRID ultra high temp.	-55 ~ 150	25 ~ 63	15 ~ 270	1000	51
	YL ☆	Lead type, HYBRID ultra high temp. high ripple	-55 ~ 125	25 ~ 63	47 ~ 680	4000	52

3 Surface Mount Aluminum Electrolytic Capacitors

Series	Features	Operating Temperature Range (°C)	General	Miniature	Long Life	Solvent Proof	Voltage Range (VDC)	Capacitance Range (μF)	Load Life Time (hours)	Page	
SMD	SC	Standard	-40 ~ 85	●			●	4 ~ 450	1.0 ~ 2200	2000	56
	RC	Standard, wide temp.	-55 ~ 105	●			●	6.3 ~ 50	1.0 ~ 1000	1000	58
	JH	Chip type, high ripple	-55(-40) ~ 105				●	6.3 ~ 450	3.3 ~ 2200	2000	59
	JM	Chip type, long life	-40 ~ 105			●	●	6.3 ~ 450	3.3 ~ 2200	3000	61
	CA	Chip type, long life	-55(-40) ~ 105			●	●	6.3 ~ 50	10 ~ 1000	5000	63
	CB	Chip type, long life, 5.5mmL height	-40 ~ 105		●	●	●	4 ~ 50	1.0 ~ 100	5000	64
	JL	Chip type, long life, for ECU	-40 ~ 105			●	●	10 ~ 50	33 ~ 470	10000	65
	ZC	5.5mmL chip type, low Impedance	-55 ~ 105				●	6.3 ~ 35	1.0 ~ 100	1000	66
	CD	Chip type, extremely low Impedance	-55 ~ 105				●	6.3 ~ 50	10 ~ 1500	2000	67
	CG ☆	Chip type, extremely low Impedance, miniature	-55 ~ 105		●		●	6.3 ~ 50	100 ~ 2200	2000	69
	CM	Chip type, extremely low Impedance, long life	-55 ~ 105			●	●	6.3 ~ 100	10 ~ 1000	3000 ~ 5000	71
	UC	Chip type, high temp. for 125°C use	-40 ~ 125				●	10 ~ 400	3.3 ~ 1000	2000	73
	UR	Chip type, high temp. low ESR. for 125°C use	-40 ~ 125		●	●	●	10 ~ 400	1 ~ 470	1000 ~ 5000	74
	UN	Chip type, low ESR for 125°C use	-40 ~ 125				●	35	47 ~ 330	2000	76
	KC	Chip type, high temp. for 135°C use, low ESR	-40 ~ 135				●	10 ~ 50	47 ~ 470	2000	77
	CW	Chip type, high reliability	-40 ~ 150				●	10 ~ 50	33 ~ 1000	1000 ~ 2000	78
	NC	5.3mmL chip, non-polarized	-40 ~ 85				●	6.3 ~ 50	1.0 ~ 47	2000	79
	CN	Chip type, wide temp. non-polarized	-55(-40) ~ 105				●	6.3 ~ 50	1.0 ~ 47	1000	80

4 Miniature Aluminum Electrolytic Capacitors

★ New series
☆ Upgrade series

Series	Features	Operating Temperature Range(°C)	General	Miniature	Long Life	Solvent Proof	Voltage Range (VDC)	Capacitance Range (μF)	Load Life Time (hours)	Page	
General Type(85°C)	SD	Standard	-40(-25) ~ 85	●			●	6.3 ~ 500	1.0 ~ 22000	2000	85
	SS	Standard, height 7mmL	-40 ~ 85		●		●	4 ~ 63	1.0 ~ 220	2000	87
	SE	Standard, height 5mmL	-40 ~ 85		●		●	4 ~ 63	1.0 ~ 330	2000	88
General Type(105°C)	RD	Standard, wide temp	-55(-40,-25) ~ 105	●			●	6.3 ~ 500	2.2 ~ 22000	1000 ~ 2000	89
	RK	Wide temp. range, height 7mmL	-55 ~ 105		●		●	4 ~ 63	1.0 ~ 68	1000	92
	RE	Wide temp. range, height 5mmL	-55 ~ 105		●		●	4 ~ 50	1.0 ~ 220	1000	93
Low profile	ZE	Height 5mmL, low impedance, high ripple	-55 ~ 105		●		●	6.3 ~ 35	1.0 ~ 100	2000	94
	ZS	Height 7mmL, low impedance, high ripple	-40 ~ 105		●		●	6.3 ~ 50	2.2 ~ 330	2000	95
	ZL	Height 7mmL, low impedance, high ripple	-40 ~ 105		●	●	●	6.3 ~ 50	2.2 ~ 330	3000	96
	ZT	Height 7mmL, long life	-40 ~ 105		●	●	●	6.3 ~ 50	2.2 ~ 330	5000	97
Low Impedance	WL	Extremely low impedance, miniaturized, wide voltage	-40(-25) ~ 105			●	●	6.3 ~ 500	1.0 ~ 15000	2000 ~ 5000	98
	MD	Ultra low impedance, high ripple	-40 ~ 105		●		●	6.3 ~ 16	470 ~ 3300	2000	101
	RZ	Extremely low impedance, high reliability	-55 ~ 105			●	●	6.3 ~ 63	1.0 ~ 15000	2000 ~ 5000	102
	MK	Ultra low impedance, miniaturized, high ripple	-40 ~ 105		●	●	●	6.3 ~ 100	1.0 ~ 15000	2000 ~ 5000	104
	MZ	Ultra low impedance, miniaturized, high ripple	-40 ~ 105		●	●	●	6.3 ~ 100	1.0 ~ 15000	2000 ~ 5000	107
	KN	Ultra low impedance, high ripple	-40 ~ 105		●	●	●	10 ~ 50	33 ~ 3300	3000 ~ 5000	109
	RP	Extremely low impedance, long life	-55 ~ 105			●	●	6.3 ~ 50	1.0 ~ 15000	4000 ~ 10000	111
	WF	Extremely low impedance, miniaturized, long life	-40 ~ 105		●	●	●	6.3 ~ 100	1.0 ~ 15000	5000 ~ 10000	113
	LZ	Ultra low impedance, long life	-40 ~ 105		●	●	●	6.3 ~ 50	10 ~ 8200	6000 ~ 10000	115
	ML	Ultra low impedance, long life	-40 ~ 105		●	●	●	6.3 ~ 100	10 ~ 10000	6000 ~ 10000	117
	LQ	For LED lighting applications, ultra low imp., high ripple	-40 ~ 105		●	●	●	6.3 ~ 120	27 ~ 8200	6000 ~ 10000	119
	LY ☆	For LED lighting applications, long life	-25 ~ 105		●	●	●	10 ~ 100	1 ~ 330	10000	121
	MH	Ultra low impedance, long life	-40 ~ 105		●	●	●	6.3 ~ 50	10 ~ 10000	7000 ~ 12000	123
	QY	For LED lighting applications, long life	-55 ~ 105		●	●	●	30 ~ 50	22 ~ 560	13000	125
	MG	For LED lighting applications, long life	-55 ~ 105		●	●	●	10 ~ 35	100 ~ 4700	20000	126
PSU, SMPS, Adapter	KS	For PSU applications, high ripple, long life	-25 ~ 85			●		420 ~ 500	47 ~ 150	8000	127
	SB	For PSU applications, high ripple, long life	-25 ~ 85			●		420 ~ 500	47 ~ 150	10000	128
	KA	For PSU applications, high ripple current	-40(-25) ~ 105			●		400 ~ 500	3.3 ~ 150	3000	129
	RH	For PSU applications, high ripple current	-40(-25) ~ 105			●		160 ~ 500	1.0 ~ 220	5000	131
	BH	For PSU applications, high ripple current	-25 ~ 105			●		200 ~ 400	2.2 ~ 100	5000	133
	KU	For PSU applications, long life, high ripple current	-40(-25) ~ 105			●		400 ~ 500	1.0 ~ 150	5000	134
	BL	For PSU applications, long life	-25 ~ 105			●		160 ~ 500	1.0 ~ 150	10000	135
	MT	For Display applications, high reliability	-40 ~ 105			●		160 ~ 500	10 ~ 470	12000	137
	KJ	For PSU applications, extremely long life, high ripple current	-40(-25) ~ 105			●		160 ~ 500	1 ~ 470	12000	139
	BN ☆	For Network applications, long life	-40 ~ 105			●		450 ~ 500	68 ~ 180	12000	141
	MP	For Display applications, long life	-40 ~ 105			●		160 ~ 500	10 ~ 470	12000 ~ 15000	142
	MJ	For PSU applications, high ripple, long life	-40(-25) ~ 105			●		160 ~ 500	3.3 ~ 470	20000	144
High temperature	RB	High temp. range, for 125°C use, miniaturized	-55(-40) ~ 125		●		●	6.3 ~ 250	1.0 ~ 15000	1000 ~ 2000	146
	WP	High temp. range, for 125°C use, long life	-40 ~ 125		●	●	●	35 ~ 100	270 ~ 4700	5000	149
	WT	High temp. range, for 125°C use, long life, low impedance	-40 ~ 125		●	●	●	6.3 ~ 100	10 ~ 3300	2000 ~ 5000	151
	LJ	For LED lighting applications, wide voltage, high temp. for 130°C use	-40(-25) ~ 130				●	10 ~ 400	1.0 ~ 4700	1000 ~ 4000	153
	BK	For PSU applications, high temp. for 125°C use	-25 ~ 125			●		160 ~ 450	2.2 ~ 47	5000	155
Special Applications	MW ☆	High ripple current, long life	-40(-25) ~ 105			●		25 ~ 500	3.3 ~ 470	5000	156
	VP ☆	For LED lighting applications, high temp. for 135°C use	-40 ~ 135				●	10 ~ 35	220 ~ 10000	3000	157
	VQ	High temp. range, for 150°C use, low impedance	-40 ~ 150				●	10 ~ 100	33 ~ 5600	1000	159
Non-polarize	NP	Standard	-40 ~ 85	●			●	6.3 ~ 250	1.0 ~ 10000	2000	161
	NS	Height 7mm	-40 ~ 85		●		●	6.3 ~ 63	1.0 ~ 47	2000	163
	NE	Height 5mm	-40 ~ 85		●		●	6.3 ~ 50	1.0 ~ 47	1000	164
	RN	Wide Temp. range	-40 ~ 105				●	6.3 ~ 100	1.0 ~ 6800	1000	165

CONTENTS

Large Aluminum Electrolytic Capacitors

★ New series
☆ Upgrade series

Series	Features	Operating Temperature Range(°C)					Voltage Range (VDC)	Capacitance Range (μF)	Load Life Time (hours)	Page	
			General	Miniature	Long life	Solvent Proof					
Snap-in Terminal	HC	Standard	-40(-25) ~ 85	●			●	6.3 ~ 550	47 ~ 100000	2000	171
	HJ	Miniaturized	-40(-25) ~ 85		●		●	10 ~ 500	56 ~ 56000	3000	174
	HF	Long life	-40(-25) ~ 85		●			160 ~ 450	56 ~ 3300	5000	177
	JR	Long life	-25 ~ 85			●		400 ~ 450	56 ~ 680	10000	179
	HE	Wide temp.range, standard	-40(-25) ~ 105	●			●	6.3 ~ 550	47 ~ 68000	2000	180
	JK	Wide temp.range, high ripple current	-40(-25) ~ 105	●				250 ~ 450	82 ~ 1500	2000	183
	HK	Wide temp.range, miniaturized	-40(-25) ~ 105		●		●	6.3 ~ 500	68 ~ 68000	3000	184
	HG	Wide temp.range, high ripple current	-40(-25) ~ 105		●			250 ~ 450	150 ~ 680	3000	187
	KG [☆]	Wide temp. High ripple current	-40 ~ 105		●			400 ~ 500	100 ~ 470	3000	188
	HH	Surge voltage	-25 ~ 105		●			450	68 ~ 560	3000	189
	HL [☆]	Wide temp.range, miniaturized, long life	-40(-25) ~ 105		●	●	●	10 ~ 500	68 ~ 56000	5000	190
	HY	Wide temp. range, long life	-40(-25) ~ 105			●		160 ~ 500	68 ~ 1800	7000	193
	JY	Long life	-25 ~ 105			●		400 ~ 500	47 ~ 470	10000	195
	JZ [★]	Long life	-25 ~ 105			●		400 ~ 450	68 ~ 330	20000	196
	HB	High temp. range, for 125°C use	-40 ~ 125				●	10 ~ 250	100 ~ 15000	1000	197
Lug Terminal	LM	For general use	-40(-25) ~ 85	●			●	16 ~ 450	68 ~ 150000	2000	199
Screw Terminal	GT	Standard	-40(-25) ~ 85	●				16 ~ 500	180 ~ 680000	2000	201
	GY	High ripple	-25 ~ 85		●			450	2700 ~ 10000	2000	204
	CU	WideTemp. range, standard	-40(-25) ~ 105	●				16 ~ 500	1000 ~ 470000	2000	205
	GF	For inverter circuits, long life	-25 ~ 85			●		350 ~ 600	1000 ~ 12000	5000	208
	GR	For inverter circuits, long life, high ripple	-25 ~ 85			●		400 ~ 450	1000 ~ 10000	5000	210
	GL	High ripple, long life	-25 ~ 85			●		350 ~ 450	1500 ~ 12000	20000	212
	EV	For inverter circuits, long life	-25 ~ 105			●		400 ~ 500	1000 ~ 6800	2000 ~ 5000	213
	EY	For inverter circuits, long life	-25 ~ 105			●		350 ~ 450	1500 ~ 12000	7000	214
Special Type	LW,SW	For welding machine	-25 ~ 85					315, 475	225 ~ 2200	-	215
	AM	For audio equipment	-40 ~ 85					16 ~ 100	470 ~ 33000	2000	216
	DF	For photo flash	-20 ~ 55					330, 360	200 ~ 1500	-	217
	AL,AY [★]	For inverter air-conditioning system	-40 ~ 85					450	470 ~ 820	5000(7000)	218
	AK	For inverter air-conditioning system, high ripple current,long life	-40 ~ 105					450	470 ~ 820	3000	219

PART NUMBER SYSTEM

● Part Number System

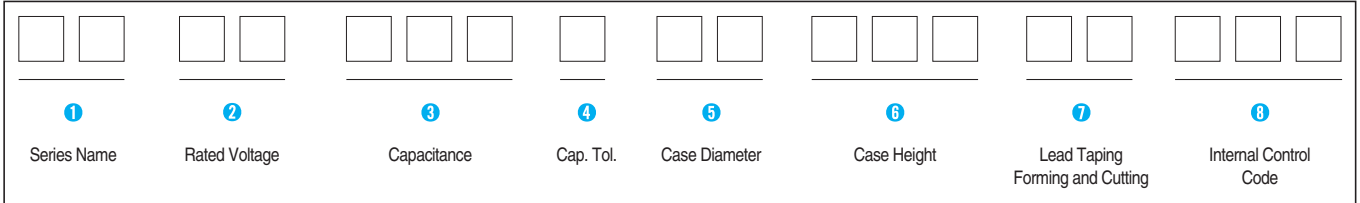

1 Series Name
See page 6

2 Rated Working Voltage

WV	2.5	4	6.3	10	16	20	25
Code	0E	0G	0J	1A	1C	1D	1E
WV	35	40	50	63	80	100	160
Code	1V	1G	1H	1J	1K	2A	2C
WV	200	250	315	350	400	450	500
Code	2D	2E	2F	2V	2G	2W	2H

3 Capacitance

ex) 4.7 μ F 475
 47 μ F 476
 470 μ F 477
 4700 μ F 478
 47000 μ F 479

4 Capacitance Tolerance

Tolerance (%)	± 10	± 20	$\begin{matrix} -10 \\ +20 \end{matrix}$	$\begin{matrix} -10 \\ +30 \end{matrix}$	$\begin{matrix} -10 \\ +50 \end{matrix}$
Code	K	M	V	Q	T

5 Case Diameter

ex) $\varnothing 4$ 04 $\varnothing 12.5$ 12
 $\varnothing 5$ 05 $\varnothing 16$ 16
 $\varnothing 6.3$ 6L $\varnothing 18$ 18
 $\varnothing 8$ 08 $\varnothing 22$ 22
 $\varnothing 10$ 10

6 Case Height

ex) 5mm 005
 11mm 011
 12.5mm 12M
 20mm 020
 31.5mm 31M
 35.5mm 35M

7 Lead Taping, Forming and Cutting

	Type	Code
Chip	Reel	VR
	Vibration Resistance Reel	VG
Lead	Bulk	BB

See page 39, 58, 89~90

ENVIRONMENTAL FRIENDLY CAPACITORS

- Production discontinuation of old series at Samwha is implemented as planned.
- Technical documents and samples are available upon the request to study alternative products.
- The following series are discontinued.
- Please use the recommended replacements in the table.

Type	Characteristics	Discontinued Series	Obsolete Year	Substitute Series	Page
SMD	85°C Standard	MC	Year 2004	SC	62
		GC			
	105°C Standard	TC	Year 2006	JH	65
	105°C 3000 hours	JC	Year 2019	JM	67
	105°C Impedance	CZ	Year 2019	CD	73
CK		Year 2020			
	130°C Standard	CF	Year 2019	KC	83
MINIATURE RADIAL LEAD	85°C Standard	SA	Year 1996	SD	91
		GA			
		SG			
	Height 7mm, high CV	SV	Year 2004		
		SK	Year 1996	SS	93
	105°C Standard	RA	Year 1994	RD	95
		RG	Year 2004		
		RV	Year 2006		
	Low Impedance Standard	RM	Year 2019	RZ	108
		WD	Year 2006		
		WA	Year 2009		
	Low Impedance	LK	Year 2018	WL	104
		RF	Year 2000		
	Extremely low Impedance, long life	RX	Year 2002	RP	117
	Low Impedance Standard	RQ	Year 2006	RP	117
	Ultra Low Impedance	MQ	Year 2019	MK	110
		WB	Year 2009	MZ	113
		WK			
	WH				
	Ultra Low Impedance	WN	Year 2009	ML	123
	Ultra Low Impedance, high ripple	MN	Year 2018	KN	115
		MB	Year 2019		
	For PSU applications, long life	SJ	Year 2018	KS	132
	High Temp. range, for 130°C, low impedance	VA	Year 2018	VP	162
	Long life	BG	Year 2015	BL	140
		PF	Year 2019		
	For PSU 105°C high ripple, long life	BD	Year 2014	KU	139
PQ		Year 2015			
RU					
	MU	Year 2018			
125°C 2000 hours, standard	RW	Year 2006	BK	160	
High Temp. range, for 155°C	VB	Year 2018	VQ	164	
	BM	Year 2019			
85°C 2000 hours non-polarized	BP	Year 2016	NP	166	
LARGE	85°C standard, snap-in	HS	Year 1994	HC	177
		KL	Year 1996		
		HQ			
		HM	Year 1999		
	105°C standard, snap-in	HD	Year 1996	HE	186
		HA	Year 1999		
	105°C 3000 hours, high ripple	HV	Year 2013	HK	190
		JG	Year 2017		
	105°C 5000 hours	JF	Year 2020	HL	196
	105°C snap-in, long life	HU	Year 2006	HY	199
	85°C standard, screw terminal	SX	Year 1994	GT	206
		SM	Year 2006		
		GK	Year 2017		
	GM	Year 2019			
85°C 5000 hours, high ripple	GN	Year 2016	GF	213	
	GH				
For photo flash	SF	Year 1996	DF	222	

■ Eco-friendly activity

● Background of Environment friendly Products

Eu declared RoHS law to restrict the using of six hazardous substances. (February, 2003) July 1, 2011 Announces recast RoHS Directive (2011/65 / EU) that restructured the existing RoHS Directive (2002/95 / EC).

Low	Contents	Enforcement Data
RoHS	Pb, Cd, Hg, Cr+6, PBBs, PBDEs	July 1, 2006. (2002/95/EC)
RoHS II	Pb, Cd, Hg, Cr+6, PBBs, PBDEs, DEHP, BBP, DBP, DIBP	January 3, 2013. (2011/65/EU)

* RoHS : Restriction of Hazardous Substances

● Allowable criteria

substance	Regulation
1) Pb - Lead	Less than 1000 mg/kg
2) Cd - Cadmium	Less than 100 mg/kg
3) Hg - Mercury	Less than 1000 mg/kg
4) Cr(VI) - Hexavalent Chromium	Less than 1000 mg/kg
5) PBBs - Polybrominated biphenyls	Less than 1000 mg/kg
6) PBDEs - Polybrominated diphenyl ethers	Less than 1000 mg/kg
7) DEHP - Bis(2-ethylhexyl) phthalate	Less than 1000 mg/kg
8) BBP - Butyl benzyl phthalate	Less than 1000 mg/kg
9) DBP - Dibutyl phthalate	Less than 1000 mg/kg
10) DIBP - Diisobutyl phthalate	Less than 1000 mg/kg

* Materials are not intentionally added and below limits by RoHS Directives

Label Marking

Packages containing products compliant with RoHS Directive are identified by the information "RoHS" (See sample label); these markings identify these products being fully compliant with the RoHS Directive



● Other eco-friendly activities

Regulated substance	Related activities
REACH_SVHC	Complies with Regulation (EC) No 1907/2006.
Halogen-Free	Voluntary reduction of harmful substances
Conflict Minerals Reporting	It follows the standardization template created by EICC® and GeSI.

* Samhwa Electric is leading the production of eco-friendly products through continuous monitoring of hazardous substances.

Application Guidelines

Correct application and strict adherence to the important information listed below, will ensure optimum performance of the capacitors over their entire specified life.

1. POLARITY

If you should reverse the polarities of an aluminum electrolytic capacitor, it would lead to short-circuited circuitry and may further result in an explosion if the unit is kept energized. SAMWHA offers unit of $\varnothing 6.3$ or more with safety vent design as the standard type in order to prevent possible accidents that may take place if the unit should be connected with its polarities reversed.

It is advisable to use non-polar capacitors for a DC circuit where the polarity is to be reversed.

2. OVERVOLTAGE

Do not apply overvoltage. When overvoltage is applied to the capacitor, leakage current increases drastically, causing heat generation, short-circuit or breakage.

3. RIPPLE LOAD

The rated ripple current given for certain conditions (Temperature, Frequency) shall not be exceeded. If so, early failure may result.

The sum of DC-bias and maximum amplitude of ripple voltage shall be within rated voltage and 0V. Electrolytic capacitors are not normally designed for AC application.

4. TEMPERATURE RANGE

Use the electrolytic capacitors according to the specified operating temperature range. Applying capacitors surpassing guaranteed conditions may cause destruction due to rapid characteristic deterioration. Usage at room temperature will ensure longer life. (When using the capacitors under -45°C , its life equals that using capacitors at -45°C)

5. CHARGE/DISCHARGE

If used in circuits in which charge and discharge are frequently repeated, the capacitance value may drop, or the capacitor may be damaged. Please consult our technical department for assistance in these applications.

6. FOR SERIES CONNECTION

Aluminum electrolytic capacitors may be connected in series, but when doing so it should be noted that the voltage distribution will be according to their leakage currents. This phenomenon may induce irregularities in voltage load and cause maximum ratings to be exceeded, this could have drastic consequences especially with high voltage capacitors. Series connected electrolytic capacitors should therefore be supplied the voltages shall be proportionally distributed by balancing resistors.

전해 커패시터를 사용할 때 다음 사항에 주의하시기 바랍니다.

1. 극성

알루미늄 전해 커패시터의 극성을 역으로 사용하면 회로가 단락되거나 커패시터가 폭발할 수 있습니다. 극성이 역으로 사용될 경우 발생 가능한 사고를 방지하기 위하여 $\varnothing 6.3$ 이상의 표준품은 방폭 구조를 갖도록 설계됩니다.

극성이 불분명하거나, 때때로 극성이 반전되는 DC 회로에는 무극성 전해 커패시터를 사용하십시오.

2. 과전압

과전압을 인가하지 마십시오.

과전압이 커패시터에 인가되면 누설전류가 급격히 증가하며, 이것은 발열이나 회로 단락의 원인이 됩니다.

3. 리플 부하

정해진 조건(온도, 주파수)에 맞는 정격 리플전류를 초과하지 마십시오. 정격치 이상의 리플전류가 커패시터에 흐르게 되면 초기 고장이 발생할 수 있습니다.

직류 바이어스 전압과 리플전압의 합은 0V에서부터 정격전압 이내이어야 합니다.

전해 커패시터는 AC 응용을 할 수 없습니다.

4. 온도 범위

알루미늄 전해 커패시터는 정격사용온도범위 내에서 사용해야 합니다. 보증 범위를 초과하는 조건에서의 사용은 급격한 특성 열화가 발생되어 파손되는 경우가 있습니다. 상온에서 사용하면 수명을 연장시키는 효과를 얻을 수 있습니다. (-45°C 이하에서 커패시터를 사용시, -45°C 와 동일한 수명을 지니게 됩니다.)

5. 충방전

충방전이 계속 반복되는 회로에 사용하면 정전용량이 감소하고 커패시터가 폭발될 수 있습니다. 이러한 회로에 제품을 적용시킬 경우 저희 회사 기술연구소로 연락 바랍니다.

6. 직렬 연결

알루미늄 전해 커패시터는 직렬로 연결하여 사용할 수 있습니다. 그러나 직렬 연결 사용시 누설전류에 의한 전압의 배분에 주의하시기 바랍니다. 누설전류에 의한 전압의 배분은 불규칙한 부하전압을 유발할 수 있으며, 정격전압의 최고치를 초과할 수도 있습니다. 직렬로 연결된 커패시터에는 전위차조정저항(balancing resistor)으로 적절히 배분된 전압을 인가하십시오.

7. FOR PARALLEL CONNECTION

When you install more than 2 capacitors in parallel, consider the balance of current flowing into the capacitors.

8. MOUNTING

The distance between the terminal holes on the circuit board should be the same as that between the lead wires or terminals of the capacitor. Excessive force in mounting on circuit boards should be avoided.

Improper insertion of the lead wires in circuit board may cause electrolyte leakage, break the lead wires or impair their connection with the internal elements.

When the distance between the two terminal holes on the circuit board cannot be reduced to that between the lead wires, lead formed capacitors are recommended.

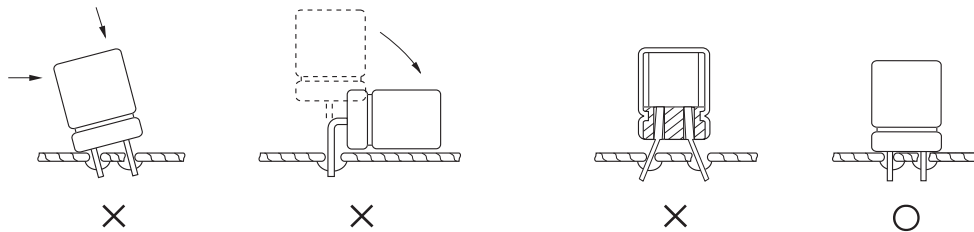

The main chemical solution of the electrolyte and the separator paper used in the capacitors are combustible. The electrolyte is conductive. When it comes in contact with the PC board, there is a possibility of pattern corrosion or short circuit between the circuit pattern which could in result smoking or catching fire. Do not locate any circuit pattern beneath the capacitor end seal.

In order to prevent possible damage by vibration on the circuit board, kindly bond our capacitors on the circuit board or use any fastening devices.

RADIAL TYPE	over Ø18 or 30mmL
SNAP-IN TYPE	over Ø22 or 40mmL

There should not be any circuit pattern or circuit wire above the capacitor safety vent.

Unless otherwise specified, following space should be made above the capacitor safety vent.

Case diameter	Ø6.3 ~ Ø16	Ø18 ~ Ø35	Ø40 ~
Space	2mm min.	3mm min.	5mm min.

If the capacitor safety vent is placed toward circuit board, the hole should be made to match the capacitor vent position.

7. 병렬 연결

두 개 이상의 커패시터를 병렬로 연결할 때 커패시터에 흐르는 전류의 배분을 고려하여 주십시오.

8. 기판 장착

회로기판에서 단자 홀(hole) 간격은 커패시터의 리드선이나 단자간의 간격과 같아야 합니다.

회로기판에 장착시 무리한 힘을 가하지 마십시오.

회로기판에 리드선을 무리하게 삽입할 경우 전해액의 누설, 리드선의 손상, 내부 요소와의 접촉부위의 파손 등이 발생할 수 있습니다.

회로기판의 홀(hole) 간격과 리드선의 간격이 맞지 않을 때에는 리드선이 가공된 커패시터를 사용하십시오.

커패시터에 사용된 전해액의 주 용매와 전해지는 가연성이며 전해액은 전도성 재질입니다.

회로기판에 전해액이 묻을 경우 패턴이 부식되거나 회로 패턴사이에 쇼트되어 발화될 수도 있으므로 커패시터 봉입구 밑에는 어떠한 회로 패턴도 설치하지 말아주십시오.

진동으로 문제시되는 회로기판에 장착하는 경우에는 반드시 기판과 제품 바닥면을 접촉시키거나 별도의 고정 장치를 사용하십시오.

RADIAL TYPE	Ø18, L치수 30mmL 이상 제품
SNAP-IN TYPE	Ø22, L치수 40mmL 이상 제품

커패시터의 안전 변 위에 회로 패턴이나 배선이 없도록 하여 주십시오.

만약 그렇지 못하면 다음과 같이 안전 변이 작동할 수 있는 공간이 있어야 합니다.

Case diameter	Ø6.3 ~ Ø16	Ø18 ~ Ø35	Ø40 ~
Space	2mm 이상	3mm 이상	5mm 이상

만약 커패시터의 안전 변이 회로 기판으로 향한다면, 커패시터 안전 변 위치의 기판에 구멍을 설치해야 합니다.

ALUMINUM ELECTROLYTIC CAPACITORS

Do not install screw terminal capacitor with end seal side down. When you install a screw terminal capacitor in a horizontal mount, the positive terminal must be in the upper position.

Screw 단자형 커패시터의 봉입구를 아래로 향하게 하지 말아 주십시오. 제품을 옆으로 놓혀 사용할 경우에는 양극 단자를 위로 향하도록 하여 주십시오.

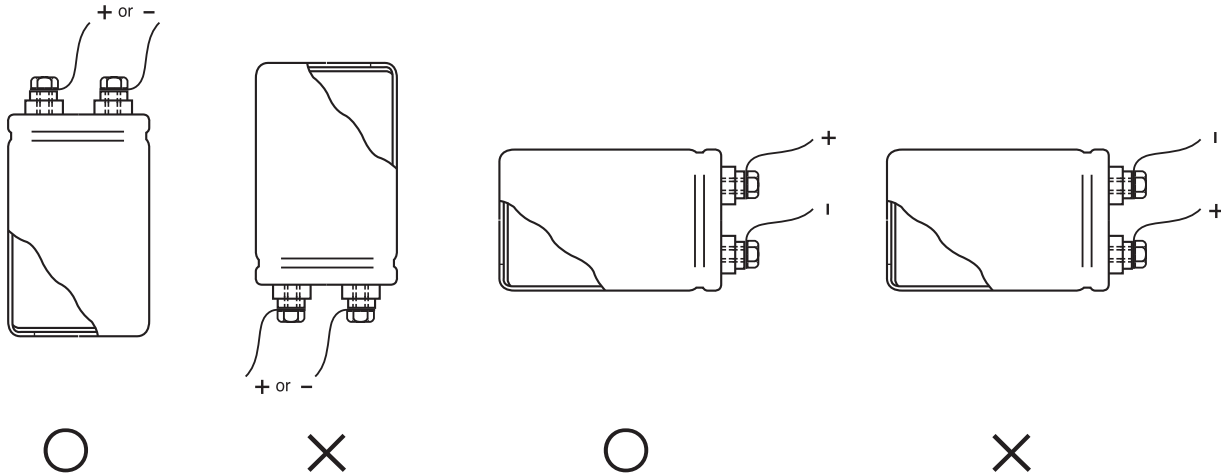

9. LEAD STRESS

Do not apply excessive force to the lead wires or terminals. If excessive force is applied to the lead wires and/or terminals, they may break and cause an open circuit. After mounting, avoid holding or applying force to the capacitor. Do not twist or carry the PC board by grasping the capacitor body after the capacitor are soldered to the PC board.

9. 리드 스트레스

커패시터의 리드선이나 단자에 무리한 힘을 가하지 마십시오. 리드선이나 단자의 단선 및 회로의 개방을 초래할 수 있습니다. 기판 장착 후에도 커패시터에 무리한 힘을 가하지 마십시오. 회로기판에 장착 후 커패시터를 잡고 이동하거나 비틀지 마십시오.

10. SOLDERING

In the dip soldering process of PC board with aluminum electrolytic capacitors mounted, secondary shrinking or crack of the sleeve may be observed when solder temperature is too high and/or dipping time is too long.

If the lead wire of other components or pattern of bothsided PC board is close to the capacitor terminal the similar failure may be also originated.

10. 납땜

알루미늄 전해 커패시터가 장착된 인쇄회로기판의 침적납땜 공정에서 납땜 온도가 너무 높거나, 지나치게 오랫동안 침적할 경우 슬리브의 2차 수축이나 갈라짐이 발생할 수 있습니다. 양면 인쇄회로기판의 패턴이나 다른 부품의 리드선과 커패시터의 단자가 아주 근접할 경우에도 위와 같은 슬리브의 이상이 발생할 수 있습니다.

Please avoid having flux adhere to any portion except the terminal. Solder iron does not touch any portion of capacitor body.

단자이외의 부분에 플럭스가 묻지 않도록 하여 주시고 커패시터에 납땜 인두가 닿지 않도록 하여 주십시오.

11. Cleaning, Mounting of the PCB after soldering

1)When you clean a PCB, halogen cleaning agents can cause corrosion of aluminum foil and lead tab. If you need to clean, please replace Isopropyl Alcohol(IPA), Water as halogenated cleaning agents.

2)5minutes either by ultrasonic, vapor or immersion cleaning method.(chip type :2minutes) Becareful not to apply mechanical stress to the terminals or lead wires

11. 납땜 후 회로기판 세정

1)인쇄회로기판 세정시 할로겐계의 세정제가 커패시터의 내부에 침투하게 되면 알루미늄 호일과 리드에 부식의 원인이 될 수 있습니다. 세척이 필요한 경우에는 할로겐계 세정제 대신 이소프로필 알콜이나 물을 사용하십시오.

2)세정조건은 초음파, 증기, 침적 등의 세척 방법에 대하여 5분(단 chip type은 2분) 단자나 리드선에 기계적인 힘이 가해지지 않도록 주의 하십시오.

3) Common type of halogenated cleaning agents are listed below

Chemical Name	Structural Formula	Representative Brand Name
Trichlorotrifluoroethane	C ₂ Cl ₃ F ₃	Freon TF, Daiflon S-3
Fluorotrichloromethane	CCl ₃ F	Freon-11, Daiflon S-1
1,1,1-Trichloroethane	C ₂ H ₃ Cl ₃	Chloroethene
Trichloroethylene	C ₂ HCl ₃	Trichlene
Methyl Chloride	CH ₃ Cl	MC

Don't use the solvents listed above as cleaning solvent agents even for solvents proof capacitors, because it has strong chemical reaction.

4) When using a latex-based adhesive on the capacitor's rubber end seal for adhesion to a PCB, corrosion may occur depending on the kind of solvent in the adhesive. Select an adhesive as an organic solvent with dissolved polymer that is not halogenated hydrocarbon.

5) Penetration Channel of Solvent and Corrosion Mechanism

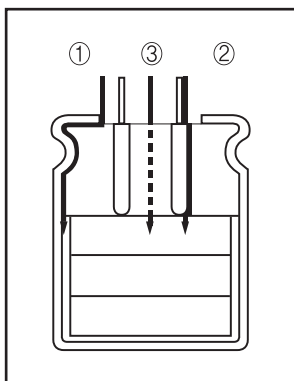

① Penetration between the rubber and the aluminum case
 ② Penetration between the rubber and the lead wires
 ③ Penetration through the rubber
 Cl-gotten inside a capacitor reacts with aluminum.
 $Al + 3Cl^- \rightarrow AlCl_3 + 3e^-$
 Then, AlCl₃ resolves in water
 $AlCl_3 + 3H_2O \rightarrow Al(OH)_3 + 3H^+ + 3Cl^-$
 Thus, the Cl⁻ ion is freed again and repeats the corrosion of aluminum.

3) 할로겐계의 세정제의 일반적 유형은 아래의 표와 같다.

화 학 명	구조식	대표 상품명
Trichlorotrifluoroethane	C ₂ Cl ₃ F ₃	Freon TF, Daiflon S-3
Fluorotrichloromethane	CCl ₃ F	Freon-11, Daiflon S-1
1,1,1-Trichloroethane	C ₂ H ₃ Cl ₃	Chloroethene
Trichloroethylene	C ₂ HCl ₃	Trichlene
Methyl Chloride	CH ₃ Cl	MC

위의 표에 열거한 물질들은 반응성이 매우 강하므로 내세척용 커패시터의 경우에도 세정제로 사용해서 안됩니다.

4) 커패시터의 밀폐용 고무에 고무계의 접착제를 사용하여 인쇄 회로 기판에 접착할 경우, 접착제의 종류에 따라 커패시터의 부식이 발생할 수 있습니다. 접착제로서는 할로겐화되지 않는 유용성 폴리머로 구성된 유기용제를 선택하십시오. 코팅(coating)을 행할 경우 제품과 기판간에 세정액이 남지 않도록 세정 직후 50~80°C에서 열풍 건조하여 주시기 바랍니다.

5) 용제의 침투경로 및 반응 메커니즘

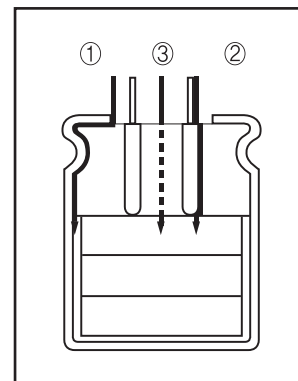

① 밀폐용 고무와 알루미늄 케이스 사이로 침투
 ② 밀폐용 고무와 리드선 사이로 침투
 ③ 밀폐용 고무를 통과하여 침투
 커패시터의 내부로 침투한 염소 이온은 아래와 같이 알루미늄과 반응을 한다.
 $Al + 3Cl^- \rightarrow AlCl_3 + 3e^-$
 이때 AlCl₃는 물에 녹아 아래와 같이 된다.
 $AlCl_3 + 3H_2O \rightarrow Al(OH)_3 + 3H^+ + 3Cl^-$
 그래서 염소이온(Cl⁻)은 다시 자유전자가 되어 알루미늄을 부식시킨다.

12. Adhesive and Coating Materials

Do not use halogenated adhesives and coating materials to fix Aluminum Electrolytic Capacitors. Flux between the surface of capacitors should be cleaned before using adhesives or coating materials. Solvents should be dried up before using adhesives or coating materials. Do not cover up all the sealing area of capacitors with adhesives or coating materials. Make coverage only partial. (The sealing area 30%)

13. INSULATION MATERIAL

Sleeve material

The standard sleeve material is P.V.C or P.E.T if exposed to xylene, toluene, etc. and then subjected to high heat, the sleeve may crack.

Case and cathode terminal

The case of capacitor is not insulated from the cathode terminal.

Dummy terminals for snap-in type

Dummy terminals are not insulated from the element. Dummy terminals are for added stability only, and should never be electrically connected to either the positive or negative terminal.

14. STORAGE

Do not store the capacitors in high temperature and high humidity conditions. Avoid direct sunlight. (Recommendable conditions : 5 to 35°C, 75% or below RH) Store the capacitors in the package. Capacitors should not be direct contact with water, brine or oil. Capacitors must not be exposed to toxic gases such as hydrogen sulfide, sulfurous acid, nitrous acid, chlorine, or ammonium.

Capacitors should be stored sealed in bag until they are actually used.

Once the sealed bag is cut open, all the parts should be used at one time. If not, then the remaining parts should be placed in a bag and sealed with tape.

In order to maintain a good solderability of the parts, shelf life of parts should not exceed 1 year.

When the capacitor is stored for a long time without applying voltage, leakage current tends to increase, due to deterioration of aluminum oxide film. This returns to normal by applying voltage. Apply voltage (Aging) before use if the capacitor is stored long time.

It is recommended to apply DC working voltage to the capacitor for 30 minutes through 1kΩ of protective series resistor.

12. 제품 고정제와 코팅

할로겐계 용제를 포함하는 고정제, 코팅제는 사용하지 말아 주십시오. 고정제, 코팅제를 사용하기 전에 기판과 콘덴서 봉구부 부분에 플럭스가 남거나 오염된 채로 놓아두지 않아 주십시오. 기판 세척제는 고정제, 코팅제를 사용할 때 콘덴서 봉구부 전체를 밀봉시키지 말아 주십시오. (봉구부의 30% 이하)

13. 절연

슬리브 재질

표준 슬리브의 재질은 P.V.C 또는 P.E.T이며, 크실렌이나 톨루엔에 노출되거나, 커패시터가 고온의 환경에서 사용된다면 슬리브가 갈라질 수 있습니다.

케이스와 음극단자

커패시터의 케이스와 음극단자는 절연이 되지 않습니다.

SNAP-IN 단자형 제품의 보조단자

보조단자는 내부요소와 절연이 되지 않습니다.

보조단자는 커패시터를 견고하게 고정시키기 위한 것이므로 양극단자나 음극단자와 전기적인 연결이 없어야 합니다.

14. 보관

커패시터를 고온, 다습 또는 직사광선의 환경에서 저장하지 마십시오.

(적정 조건 : 5~35°C, 75% 이하의 상대습도)

커패시터를 포장된 상태로 보관하여 주십시오. 커패시터에 물, 소금물 또는 기름이 직접 닿지 않도록 주의하여 주십시오.

커패시터를 유화수소, 아황산, 질산 염소, 암모늄 등의 유해한 가스에 노출된 환경에서 보관하지 말아 주십시오.

커패시터를 실제 사용하기 전까지 밀봉된 Bag에 넣어 보관하십시오. 밀봉된 포장을 뜯은 후 모든 부품을 즉시 사용하십시오. 전부 사용하지 않는다면, 남은 부품은 Bag에 넣어 테이프로 밀봉해 보관하십시오.

부품들의 수명과 우수한 납땜성을 유지하기 위해서는 방치 후 1년을 초과하지 않아야 합니다.

전압을 인가하지 않은 상태에서 장기간 보관된 커패시터는 누설 전류가 증가하는 경향이 있습니다.

그러나 커패시터에 전압을 인가하면 정상으로 환원됩니다. 장기간 보관되었던 커패시터는 전압처리 후 사용하여 주십시오.

전압처리는 1kΩ의 보호저항을 통해 직류 정격전압을 30분 동안 인가해야 합니다.

15. EMERGENCY ACTION

When the safety vent is Open and some gas blows out from the capacitor, please turn the main switch of the equipment off or pull out the plug the power outlet immediately.

During vent operation, extremely hot gas(over 100°C) and electrolyte may blow out from the capacitors. Do not stand close to the capacitors. In case of eye contact, flush the poen eyes with large amout or clean water immediately, do not swallow. do not touch electrlyte but wash skin with soap and water in case of skin contact.

16. DESTRUCTING CAPACITORS & OTHERS

In case of destructing our capacitors, Burn capacitors up after making holeson them or scrapping. When you try to destroy them by fire, you may expect explosion in the capacitors.

In order to prevent hazardous gas like chlorine gas, burn our capacitors on high temperature range. Burning sleeve on low temperature may cause producing chlorine gas.

When you do not have burning facilities, please contact special industrial wastes processing companies.

Capacitors may accumulate charge maturally during long storage time. In this case, the capacitors should be subject to voltage treatment through about 1k Ω resistor before use.

since it has possibilities for electric shock or burns, kindly, discharge it at the level of 1k Ω in advance.(sufficient and safe resistance values should be considered before applying)

For methods of testing, refer to KS C IEC 60384-4 (JIS C 5101-1, JIS C 5101-4)

Capacitors case size and other product standards specified in this catalog may be changed or modified without notice for improvement of quality.

15. 응급 조치

커패시터 사용 중 커패시터 안전 변이 열려 Gas가 분출될 경우 SET 의 전원 장치의 스위치를 끄거나 플러그를 즉시 뽑아 주십시오.

커패시터의 안전변 동작시 +100°C를 초과하는 Gas 분출 및 전해액 이 흘러 내릴 수 있으므로 가까이 다가가지 마십시오. 분출한 Gas가 눈에 들어가거나 흡입한 경우에는 즉시 물로 눈을 씻거나 삼키지 말고 입안을 닦아주시기 바랍니다. 전해액은 만지지 말고 만약 피부에 묻었을 경우 물이나 비누로 닦아 주십시오.

16. 커패시터 폐기 및 기타

커패시터를 폐기할 경우에는 구멍을 내거나 충분히 부순 후에 소각하여 주십시오. 소각시 커패시터가 폭발하는 경우도 있습니다.

커패시터는 외장 슬리브(PET)가 씌어져 있기 때문에 고온 소각을 하여 주십시오. 저온 소각을 하면 염소 Gas 등의 유해 Gas가 발생하는 원인이 됩니다.

커패시터를 소각하지 않은 경우에는 전문 산업폐기물 처리업체에 의뢰하여 주십시오.

커패시터는 재기 전압이 발생할 경우가 있습니다. 이런 경우에는 사용 전에 약 1k Ω 의 저항을 통해 방전 처리 후 사용하여 주십시오.

감전 및 화상의 우려가 있으므로 사용전에 1k Ω (전압, 용량에 따라 충분히 여유를 고려한 저항 선택)의 저항을 통해서 방전처리를 해 주십시오.

기타 시험규격에 대해서는 KS C IEC 60384-4 (JIS C 5101-1, JIS C 5101-4)를 참조 바랍니다.

카다로그에 규정된 제품 사이즈 및 제품 기준은 품질 개선의 필요 성으로 인하여 귀사에 통지없이 변경될 수 있습니다.

General introduction

Rated capacitance

The capacitance value for which the capacitor has been designed and which is usually indicated upon it.

Tolerance on rated capacitance

Preferred values of tolerance on rated capacitance are:
-20/+20%, -10/+20%, -10/+30%, -10/+50%, -10/+10%

Rated voltage

The maximum direct voltage, or peak value of pulse voltage which may be applied continuously to a capacitor at any temperature within operating temperature range.

Ripple voltage

An alternating voltage may be applied, provided that the peak voltage resulting from the alternating voltage, when superimposed on the direct voltage, does not exceed the value of rated voltage or fall under 0V and that the ripple current is not exceeded.

Surge voltage

The maximum instantaneous voltage which may be applied to the terminations of the capacitor for a specified time at any temperature with the operating temperature range.

Rated voltage (VDC)	4	6.3	10	16	25	35
Surge voltage (VDC)	5	8	13	20	32	44

Rated voltage (VDC)	40	50	63	80	100	160
Surge voltage (VDC)	50	63	79	100	125	200

Rated voltage (VDC)	200	250	275	315	350	375
Surge voltage (VDC)	250	300	316	365	400	425

Rated voltage (VDC)	400	420	450	500	550	600
Surge voltage (VDC)	450	470	500	550	600	650

Equivalent series resistance (ESR)

The ESR of an equivalent circuit having capacitance, inductance and resistance in series measured with alternating current of approximately sinusoidal waveform at a specified frequency.

$$ESR = \frac{\tan \delta}{2\pi fC}$$

where,

f = measurement frequency (120Hz)

C = measurement capacitance (F)

Dissipation factor ($\tan \delta$)

The power loss of the capacitor divided by the reactive power of the capacitor at a sinusoidal voltage of specified frequency.

Leakage current

Leakage current flows through a capacitor when DC voltage is applied in correct polarity. It is dependent on voltage, temperature and time.

Ripple current

Any pulsating voltage (or ripple voltage superimposed on DC bias) across a capacitor results in an alternating current through the capacitor. Because of ohmic and dielectric losses in the capacitor, this alternating current produced an increase of temperature in the capacitor cell. The capacitor should be used within specified permissible ripple current in each standard products table.

In other condition of ambient temperature and frequency, ripple current multiplied by following multiplier can be applied as maximum permissible ripple current.

Failure rate

The failure rate of an aluminum electrolytic capacitor follows a bathtub curve.

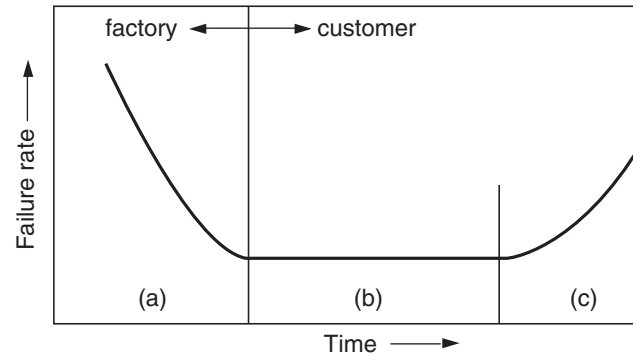

- (a) initial failure period (infant mortality)
- (b) random failure period (useful life period)
- (c) wear-out failure period

Expected life - (*for reference)

Temperature, humidity, ripple current and atmospheric pressure etc. have influence on the life of aluminum electrolytic capacitors. Among them, temperature has the greatest effect on life of capacitors. The relationship between ambient temperature and life of capacitor can be explained to so-called ARRHENIUS equation, generally the life of capacitor is reduced approximately by one-half for each temperature increase of 10°C. The life acceleration equation computes as shown below.

$$L = L_s \times 2^{\frac{T_s - (T + \Delta T)}{10}}$$

L : Lifetime of capacitor to be estimated (Hour)
 L_s : Base life time of capacitor (Hour)
 T_s : Maximum operating temperature shown in catalog (°C)
 T : Ambient temperature (°C)
 ΔT : An increase temperature produced by internal heating due to actual operating ripple current. (°C)

Expected life chart - (*for reference)

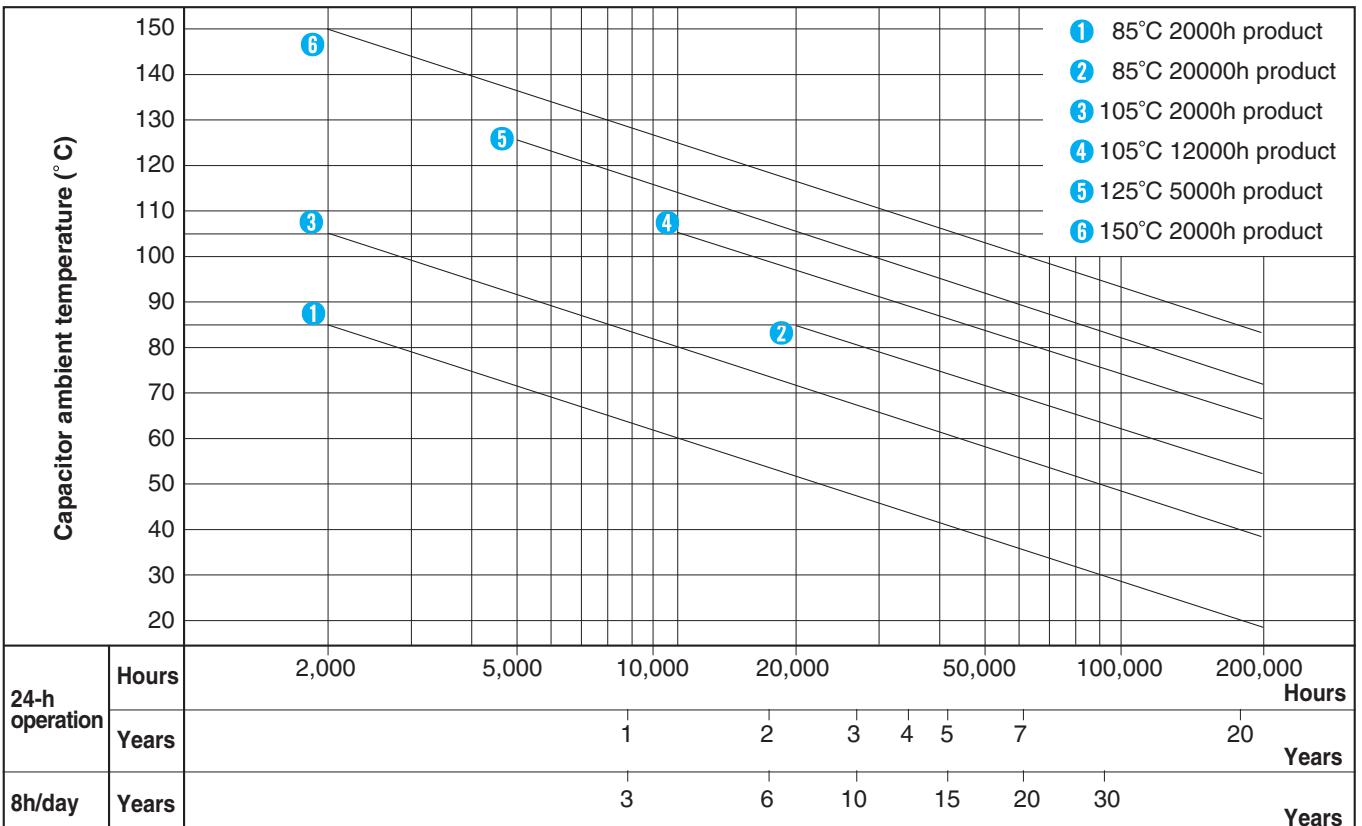

Reflow soldering method for the chip aluminum electrolytic capacitor

1. Recommended conditions for reflow soldering

The chip aluminum electrolytic capacitor is subjected to soldering by reflow method.

Temperature and time conditions of reflow soldering shall be set as per each temperature profile shown below as a standard. The following are recommended conditions in the case of reflow soldering method for the chip aluminum electrolytic capacitor.

- (1) The capacitor shall not be subjected to either flow or dip soldering method.
- (2) Avoid soldering twice by reflow. The number of reflow time for chip aluminum electrolytic capacitor shall be once basically. If this type of capacitor has to be inevitably subjected to the reflow twice, enough cooling time between the first and the second reflow (at least more than 30 minutes) shall be taken to avoid the consecutive reflows by all means.
- (3) The touch up work with a soldering iron is allowed after the reflow soldering (Temperature of soldering iron : MAX 400°C, Time : 5 sec.), provided that carefully attention shall be paid lest a soldering iron should directly touch the capacitor body or its resin bottom base.

2. RECOMMENDED REFLOW SOLDERING CONDITIONS

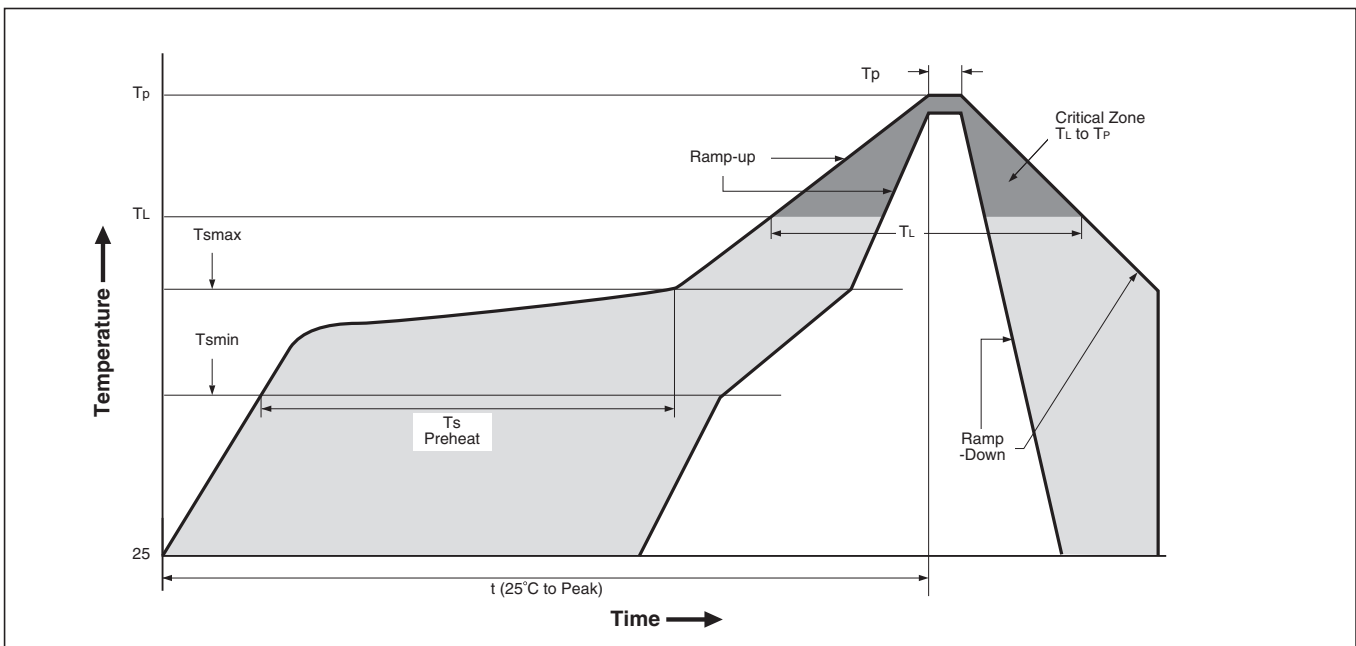

Profile Feature	Soldering condition	
	Ø4 ~ Ø10	Ø12.5
Average Ramp-up Rate (TL to TP)	3°C / second max.	3°C / second max.
Preheat	Temperature Min. (Ts min)	150°C
	Temperature Max. (Ts max)	200°C
	Time (Ts min to Ts max)	60 ~ 150 seconds
Ts max to TL -Ramp-up Rate	3°C / second max.	3°C / second max.
Time maintained above	Temperature (TL)	217°C
	Time (tL)	60 ~ 90 seconds
Peak/classification Temperature (TP)	250°C	240°C
Time within 5°C of actual peak temperature (TP)	10 seconds max.	10 seconds max.
Ramp-Down rate	3°C / second max.	3°C / second max.
Time 25°C to peak temperature	8 minute max.	8 minute max.

1 Green-Cap(ELECTRIC DOUBLE LAYER CAPACITORS)

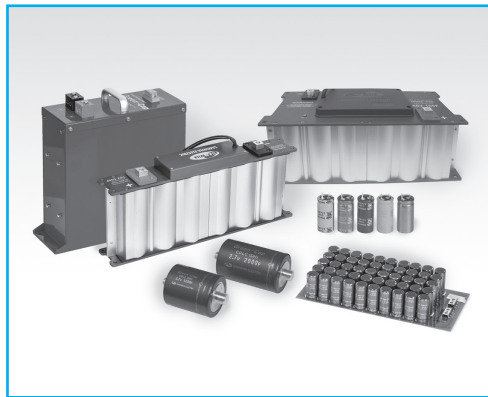

Green-Cap (ELECTRIC DOUBLE LAYER CAPACITORS)

Electric double layer capacitor(EDLC) is a next-generation energy storage device. In recent years, there has been much exploration of new uses for EDLC, and it is expected that they will become even more commonly used in the future.

What is electrical double layer capacitor (EDLC)?

A conventional capacitors have a dielectric sandwiched between two opposing electrodes. An aluminum electrolytic capacitor, as an example, uses an aluminum oxide film as a dielectric. However, EDLC does not have a dielectric. EDLC uses the electric double layer to function as the dielectric of activated carbon, therefore EDLC does not use a chemical reaction such as a redox reaction but rather store electricity by means of the physical adsorption of ions to the large specific surface area of activated carbon. EDLC consists of environmentally friendly active carbon and an organic solvent, whereas a conventional battery is made from heavy metals such as lead. EDLC does not harm the environment.

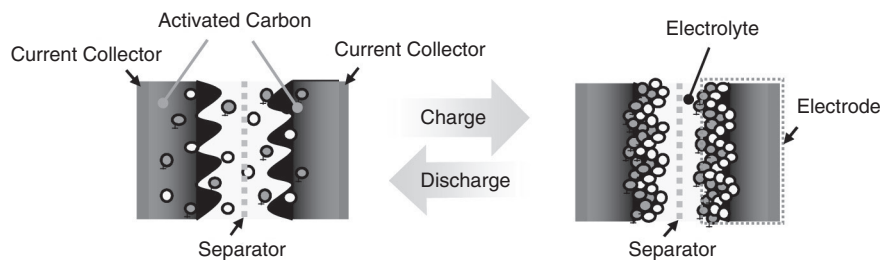

Electric Double Layer Capacitor Principle

Product Features

- ▷ Stable charge and discharge cycle
 - Life is not affected by charging/discharging cycles because there is no chemical reaction
- ▷ The advantages of EDLCs over rechargeable batteries
 - Very safe, No risk of explosion or ignition
 - Environmentally-friendly, with no heavy metals used
 - Rapid charging and discharging (at heavy current)
 - Long cycle life, charging / discharging tens of thousands of times
 - Wide range of temperatures, operation even at low temperatures
 - Recycling is unnecessary (required for batteries)
- ▷ Character of Energy Storage Device

Section		EDLC	Ni-MH	LiB
Voltage (Operating Range)		2.7 (2.7 ~ 0)	1.2 (1.4 ~ 0.9)	3.7 (4.2 ~ 3.0)
Operating Temperature Range		-40 ~ 65°C	Charge : 0 ~ 45°C	Charge : 0 ~ 45°C
High Temperature Spec.	Test Condition	Max. Operating Temp. and Max. Operating Voltage	Cycle life by Temperature	Max. Operating Temp. and Max. Operating Voltage
	Guarantee	1500hrs	0 ~ 20°C: 500 cycle	168hrs
Electrolyte	Solvent	AC / PC	KOH	EC
	Salt	Salt		LiPF6
Dangerous		None	Corrosiveness	Firing, Explosion
Eco - friendly		Very good	Good	Bad

Technical Data

CHART 1

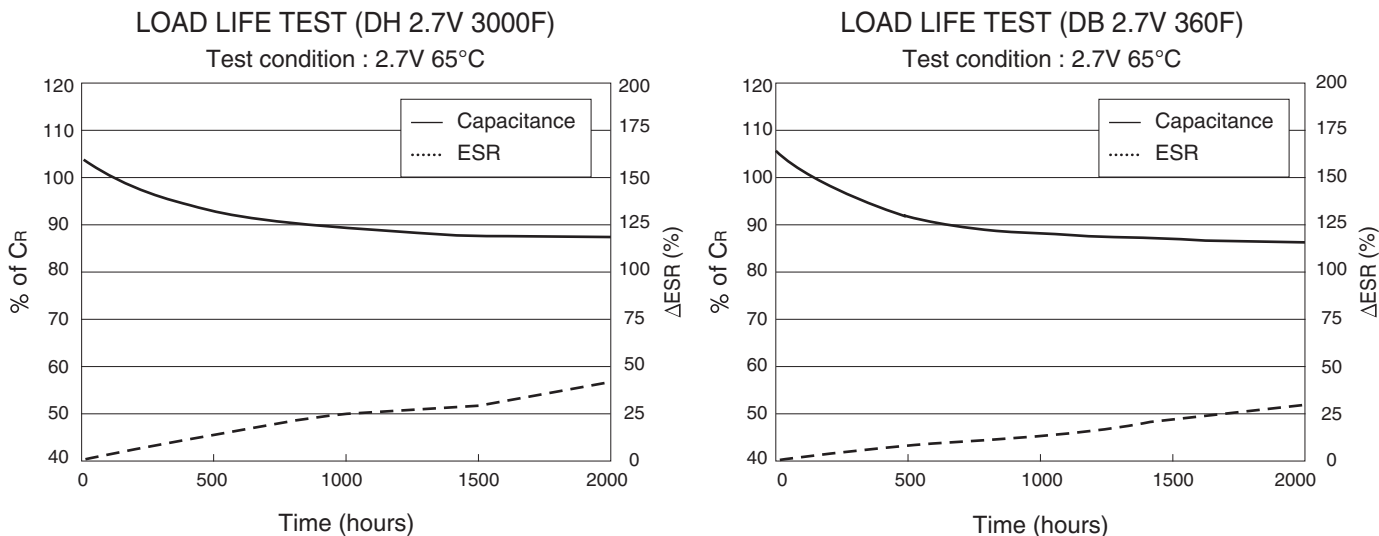

CHART 2

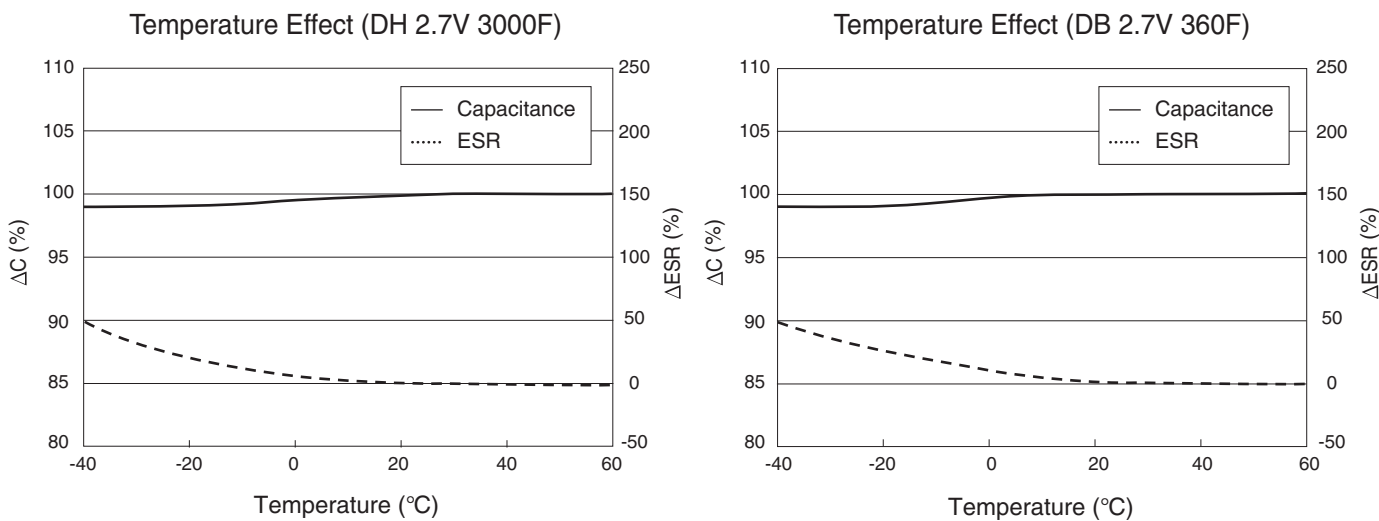
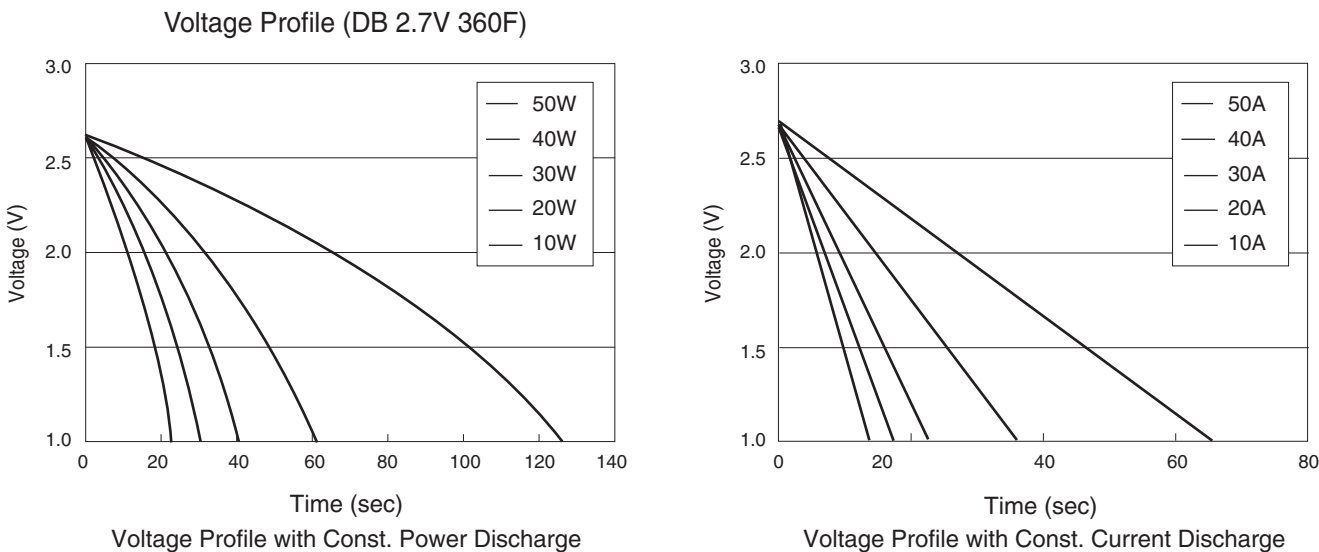

CHART 3



Application Guidelines

1. Polarity

Be sure verify the polarity of the capacitor before use. If a reverse voltage is applied for a long time, capacitor lifetime is shortened and serious damage such as electrolyte leakage may occur.

Further more, there may be leftover electric charge from capacitor testing that could damage other circuit components such as the low-withstanding voltage parts of semiconductors, etc.

2. Voltage

If a Green-Cap is used at a voltage exceeding its rated voltage, not only is its life shortened, but depending on the actual voltage, gas generated by electrochemical reactions inside the capacitor may cause it to leak or rupture

3. Ambient Temperature

(1) Capacitor life is affected by operating temperature. In general, lowering ambient temperature by 10°C will double the life of a capacitor. Use the capacitor at the lowest possible temperature under the maximum guaranteed temperature.

(2) Operation above the maximum specified temperature not only shortens capacitor life, but can also cause serious damage such as electrolyte leakage.

Verify the operating temperature of the capacitor by taking into consideration not only the ambient temperature and temperature inside the unit, but also the radiation from heat generating elements inside the unit (power transistors, IC's, resistors, etc.) and self-heating due to ripple current.

Be careful not to place heat-generating elements across from the capacitor on the opposite of the PCB.

4. Ripple Current

Green-Cap has a higher internal resistance than do electrolytic capacitors and are more susceptible to internal heat generation when exposed to ripple current. When the temperature of the element rises, a reacting current flows inside the Green-Cap, generating reaction products and raising internal resistance even further. This makes it difficult to maintain capacitance. Set the allowable limit for the ripple current-induced rise in capacitor temperature to 3°C measured at the surface of the capacitor

5. Heat Stress During Soldering

Excessive heat stress may result in the deterioration of the electrical characteristics of the capacitor, loss of air-tightness, and electrolyte leakage due to the rise in internal pressure

(1) If the tip of the soldering iron touches the capacitor's external sleeve, the sleeve will melt or break.

(2) Use the general reference chart bellow to set soldering temperature and time.

(3) When soldering with a soldering iron, do not touch the tip to the body of the capacitor.

Minimize the time that soldering iron is in contact with the capacitor terminals.

(4) When using equipment such as a UV curing oven for pre-heating and adhesive hardening, do not set the temperature above 150°C.

If the temperature is higher than this, the external sleeve may crack and the end seal may suffer reduced performance.

(5) Never perform reflow soldering on Green-Cap using infrared or atmospheric methods.

6. Circuit Board Cleaning

Circuit board can be immersed or ultrasonically cleaned using suitable cleaning solvents for up to 5 minutes and up to 60°C maximum temperature. The board should be thoroughly rinsed and dried. Recommended cleaning solvent include. Pine Alpha ST-100S, Sunelec B-12, DK beclear CW-5790, Aqua Cleaner 210SEP, Cold Cleaner P3-375, Telpen Cleaner EC 7R, Clean-thru 750H, Clean-thru 750L, Clean-thru 710M, Techno Cleaner 219, Techno Care FRV-1

- Consult with us if you are using a solvent other than any of those listed above
- The use of ozone depelting cleaning agents are not recommended in the interest of protecting the environment

7. CONNECT IN SERIES

Voltage balancing is needed to ensure uniform voltage distribution across each capacitor, if capacitors are connected in series to gain higher rated voltage.

8. CONSIDERATION TO ASSEMBLY CONDITION

In designing a circuit, the following matters should be ensured in advance to the capacitor's assembly on the printed wiring board (PW board).

Design the appropriate hole spacing to match the lead pitch of capacitors.

Do not locate any wiring and circuit patterns directly above the capacitor's vent.

Ensure enough free space above the capacitor's vent. The recommended space is specified in the catalog or specification sheets.

In case the capacitor's vent is facing the PW board, make a gas release hole on PW board.

The sealing side of the screw terminal type should not face down in the application.

When the capacitors are mounted horizontally, the anode screw terminals must be positioned at the upper side.

9. STORAGE

- (1) Capacitors should not be stored in high temperatures or where there is a high level of humidity. The suitable storage condition is 5°C~35°C and less than 75% in relative humidity.
- (2) Capacitors should not be stored in damp condition such as water, saltwater spray or oil spray.
- (3) Do not store capacitors in an environment full of hazardous gas (hydrogen sulfide, sulfurous acid gas, nitrous acid, chlorine gas, ammonia or bromine gas).
- (4) Capacitors should not be stored under exposure to ozone, ultraviolet rays or radiation.
- (5) In order to maintain a good solderability of the parts, shelf life of parts should not exceed 1 year.
- (6) When the capacitor is stored for a long time without applying voltage, leakage current tends to increase. This returns to nominal by applying voltage. Apply voltage (Aging) before use if the capacitor is stored long time. It is recommended to apply DC working voltage to the capacitor for 30 minutes.

10. TECHNICAL INFORMATION

Capacitance, DCESR Test Condition :

Constant current charge with 10mA/F to V_R .

Constant voltage charge at V_R for 5 min.

Constant current discharge with 10mA/F to 0.4 V_R .

Max. Peak Current : Current for 1 sec discharge from the rated voltage to the half of it in constant current discharge, The stated maximum (peak current) should not be used in normal operation and is only provided as a reference value.

$$I = \frac{1/2 V_R}{\Delta t / C + ESR_{DC}}$$

Energy

$$\text{Max. Stored Energy(Wh), } E_{max} \text{ (Wh)} = \frac{1/2 CV_R^2}{3600}$$

$$\text{Specific Energy(Wh/kg)} = \frac{E_{Max}}{\text{weight}}$$

Cycle Life Test Condition

- 1-minute cycle at room temperature
- Constant current charge from $1/2V_R$ to V_R .
- Constant current discharge from V_R to $1/2V_R$.
- Repeat the cycle for the desired number of times.

PART NUMBER SYSTEM

● Single Cell Part Number System

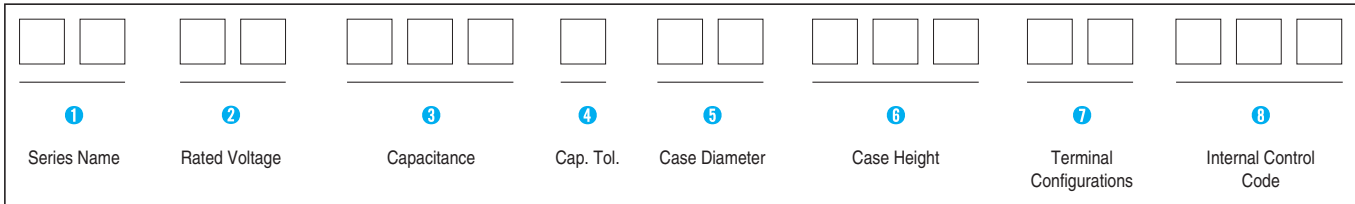

1 Series Name
See page 6.

2 Rated Working Voltage

WV	2.5	2.7	2.85	3.0
CODE	0E	5U	5R	0U

3 Capacitance

ex) 1F 105
10F 106
100F 107
1000F 108

4 Capacitance Tolerance

Tolerance (%)	± 20	0~20%
Code	M	W

5 Case Diameter

ex) $\varnothing 10$ 10
 $\varnothing 16$ 16
 $\varnothing 18$ 18

6 Case Height

ex) 20mm 020
25mm 025
30mm 030

7 Terminal Configurations

Terminal Configurations	Code
Radial Type(LEAD)	BB
Snap-In for Soldering	HA
Lug Terminal for Soldering	LG
Screw Terminal Type	SB
Threaded Terminal Type	TH
Weldable Terminal Type	WD

● Module Part Number System

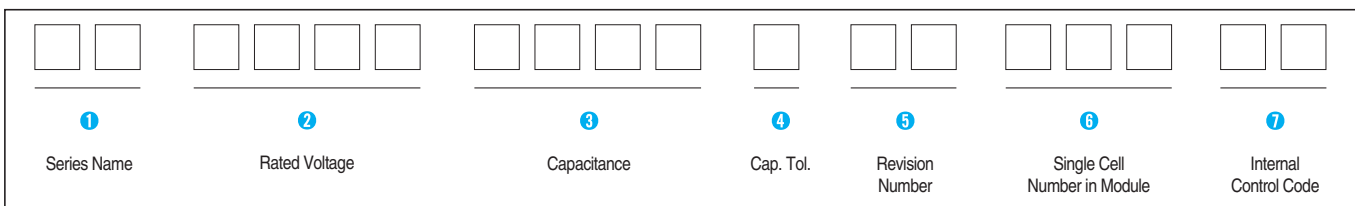

1 Series Name
See page 6.

2 Rated Working Voltage

ex) 5.0V 0050
13.5V 0135
135V 1350

3 Capacitance

ex) 1.6F 0016
16F 0160
160F 1600

4 Capacitance Tolerance

Tolerance (%)	0 ~ +20
Code	W

5 Revision Number

ex) 01, 02

6 Single Cell Number in Module

ex) 10ea 010

PACKING

● BLUCK TYPE PACKING

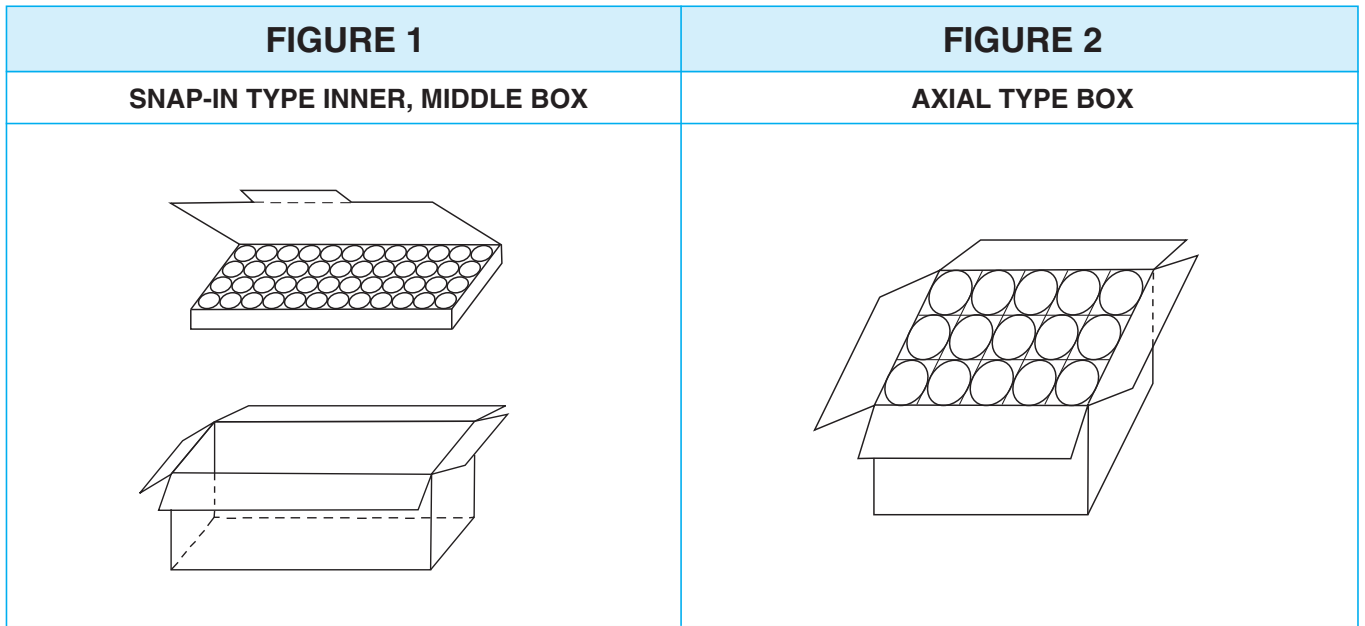

● SNAP-IN TYPE PACKING Quantity (pcs) / BOX (FIGURE 1)

SIZE		SNAP-IN(QUANTITY)	
ØD	L	INNER BOX	MIDDLE BOX
22	45, 47, 50	150	450
30	45	50	200
	60	50	150
35	50 ~ 85	50	150

● AXIAL TYPE PACKING Quantity (pcs) / BOX (FIGURE 2)

SIZE		AXIAL(QUANTITY)
ØD	L	
60	51 ~ 138	20

● RADIAL TYPE PACKING

● PACKING QUANTITY (pcs) / BOX

SIZE		BULK(QUANTITY)		
ØD	L	V-Bag	INNER BOX	MIDDLE BOX
8	20	300	2400	9600
10	20	200	1600	6400
	30	200	1200	4800
12.5	25	100	900	3600
16	25	50	500	2000
18	32	50	400	1600
	40	50	300	1200
22	45	50	150	600

Green-Cap (ELECTRIC DOUBLE LAYER CAPACITORS)

DM Green-Cap Module

- Low internal resistance
- Balancing and overvoltage protection of individual cell
- Efficient heat transfer to outside

Application

- Next Generation Vehicle(FCEV, HEV) & Heavy Duty Transportation
- Short term UPS and telecommunications
- Portable Power Tool
- Wind Turbine Pitch System
- Electric Scooter
- Heavy Duty Transportation
- Golf Car

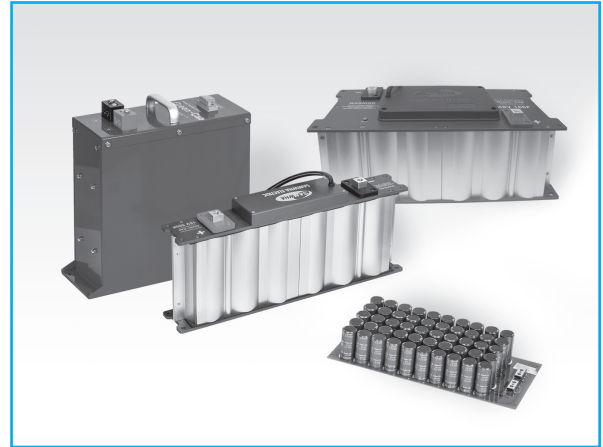

● Product & Spec.

Item	Characteristics	
Capacitance tolerance	0% ~ +20%	
Operating temperature range	-40 ~ +65°C, -40 ~ +85°C	
Storage Temperature Range	-40 ~ +70°C	
Temperature characteristics	Capacitance change	Within ±5% of initial value at +20°C
	Internal resistance change	Within 150% of initial value at +20°C
Endurance (65°C)	Test time	1500 hours (5.4V products are for 1000 hours)
	(1) Capacitance change	▲ Within ±30% of initial specified value
		● Within ±20% of initial specified value
(2) Internal resistance change	Less than 100% of specified value	
Shelf life (65°C)	After 1500 hours no load test same as endurance	
Life Time at RT ⁽¹⁾⁽²⁾ (held continuously at Rated Voltage)	10 years	(1) Δ LCI < 30% and Δ ESR < 200% of initially specified value, respectively and LC < specified value
Cycle Life (25°C) ⁽¹⁾⁽²⁾	▲	500,000 cycles
	●	1,000,000 cycles

Part Number	Rated Voltage	Capacitance (F)	ESR, 1KHz (mΩ)	ESR, DC (mΩ)	Max. Continuous Current (A)		Max. Peak Current	Max. Stored Energy (Wh)	Specific Energy (Wh/kg)	Dimension(mm)			Weight (kg)	Cycle Life
					Δ T=15°C	Δ T=40°C				L	W	H		
DM00540015W01002	5.4	1.5	120	180	0.2	0.33	3.2	0.006	1.79	22.0	8.5	17.0	0.003	▲
DM00540025W01002	5.4	2.5	100	140	0.33	0.55	5.0	0.010	2.03	22.0	10.5	21.0	0.005	▲
DM00540050W01002	5.4	5.0	60	100	0.65	1.09	9.0	0.020	2.89	32.0	10.5	21.0	0.007	▲
DM01500666W01006	15	66.6	23.0	27.4	12	20	191.0	2.08	2.60	247	46	76	0.8	▲
DM01622000W01006	16.2	200.0	2.5	3.6	84	140	941.8	7.29	1.78	418	68	115	4.1	●
DM01622666W01006	16.2	266.6	2.2	3.2	90	150	1165.4	9.72	2.11	418	68	126	4.6	●
DM01623333W01006	16.2	333.3	1.8	2.5	100	167	1472.7	12.15	2.38	418	68	143	5.1	●
DM01625000W01006	16.2	500	1.4	2.0	120	200	2025.0	18.23	3.04	418	68	179	6	●
DM04860666W01018	48.6	66.6	7.6	10.8	84	140	941.8	21.87	2.19	418	191	115	10	●
DM04860888W01018	48.6	88.8	6.5	9.7	90	150	1165.4	29.16	2.54	418	191	126	11.5	●
DM04861111W01018	48.6	111.1	5.4	7.6	100	167	1472.7	36.45	2.92	418	191	143	12.5	●
DM04861666W01018	48.6	166.6	4.3	6.0	120	200	2025.0	54.68	3.65	418	191	179	15	●
DM09000100W01036	90	10.0	138.2	164.2	12	20	170.3	11.25	1.41	290	110	268	8	▲

Note : Other Green-Cap modules are supplied on custom-made basis. Dimension and Weight could be changed.
The contents of this document are subject to change without notice.

DH Axial Type, Standard Series

- High Power Density
- Rapid charge and discharge
- Ultra-low internal resistance



Item	Characteristics	
Operating temperature range	-40 ~ +65°C	
Rated Voltage	2.7 VDC	
Capacitance tolerance	0% ~ +20%	
Temperature characteristics	Capacitance change	Within ±5% of initial value at +20°C
	Internal resistance change	Within 100% of initial value at +20°C
Endurance (65°C)	Test time	1500 hours
	Capacitance change	Within ±20% of specified value
	Internal resistance change	Less than 100% of specified value
Shelf life (65°C)	After 1500 hours no load test same as endurance	
Life Time at RT ⁽¹⁾	10 years	(1) IΔCI < 20% and ΔESR < 100% of specified value, respectively and LC < specified value
Cycle Life (25°C) ⁽¹⁾⁽²⁾	1,000,000 cycles	(2) Cycle : between rated voltage and half rated voltage under constant current at 25°C

● DRAWING

Unit : mm

Threaded Type

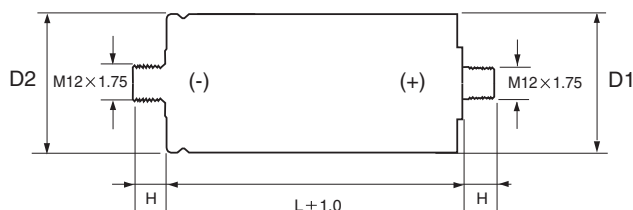
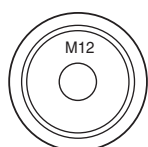

Size (mm)		
H	D1	D2
(±0.2)	(±0.2)	(±0.5)
13.0	∅60.4	∅60.7

Weldable Type

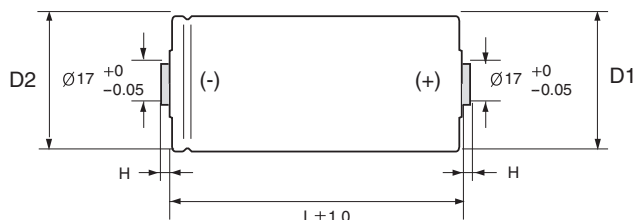
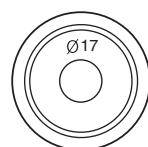

Size (mm)		
H	D1	D2
(±0.2)	(±0.2)	(±0.5)
3.0	∅60.4	∅60.7

● CHARACTERISTIC LIST & DIMENSIONS

Rated Voltage	Capacitance (F)	ESR, 1KHz (mΩ)	ESR, DC (mΩ)	LC (72hr) (mA)	Max Continuous Current(A)		Max Peak Current(A)	Specific Energy		Weight (g)	Volume (ml)	Dimension ∅D × L(mm)
					ΔT=15°C	ΔT=40°C		(Wh/kg)	(Wh/L)			
2.7	1200	0.30	0.33	2.7	98	159	1160	4.05	5.73	300	212	60.4 × 74
	1600	0.25	0.28	3.0	115	188	1492	4.76	6.65	340	244	60.4 × 85
	2000	0.24	0.27	4.0	126	206	1753	5.06	6.93	400	292	60.4 × 102
	3000	0.20	0.23	5.0	150	245	2396	5.79	7.68	525	395	60.4 × 138
	3400	0.25	0.28	9.2	130	210	2351	6.50	8.71	530	395	60.4 × 138

Green-Cap (ELECTRIC DOUBLE LAYER CAPACITORS)

DV Axial Type, High Voltage Series

- High Power Density
- Rapid charge and discharge
- Ultra-low internal resistance

DH → DV
High Voltage



Item	Characteristics	
Operating temperature range	-40 ~ +65°C	
Rated Voltage	2.85, 3.00 VDC	
Capacitance tolerance	0% ~ +20%	
Temperature characteristics	Capacitance change	Within ±5% of initial value at +20°C
	Internal resistance change	Within 100% of initial value at +20°C
Endurance (65°C)	Test time	1500 hours
	Capacitance change	Within ±20% of specified value
	Internal resistance change	Less than 100% of specified value
Shelf life (65°C)	After 1500 hours no load test same as endurance	
Life Time at RT ⁽¹⁾	10 years	(1) IΔCI < 20% and ΔESR < 100% of specified value, respectively and LC < specified value
Cycle Life (25°C) ⁽¹⁾⁽²⁾	1,000,000 cycles	(2) Cycle : between rated voltage and half rated voltage under constant current at 25°C

● DRAWING

Unit : mm

Threaded Type

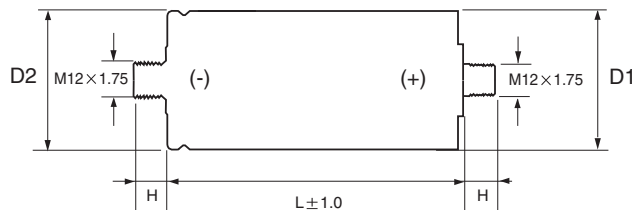
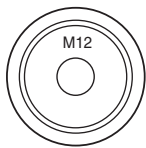

Size(mm)		
H	D1	D2
(±0.2)	(±0.2)	(±0.5)
13.0	∅60.4	∅60.7

Weldable Type

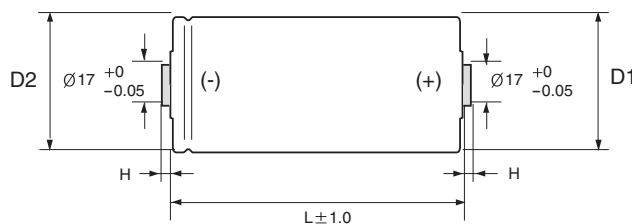
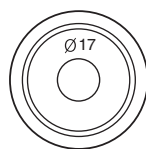

Size(mm)		
H	D1	D2
(±0.2)	(±0.2)	(±0.5)
3.0	∅60.4	∅60.7

● CHARACTERISTIC LIST & DIMENSIONS

Rated Voltage	Capacitance (F)	ESR, 1KHz (mΩ)	ESR, DC (mΩ)	LC (72hr) (mA)	Max Continuous Current(A)		Max Peak Current(A)	Specific Energy		Weight (g)	Volume (ml)	Dimension ∅D×L(mm)
					ΔT=15°C	ΔT=40°C		(Wh/kg)	(Wh/L)			
2.85	1200	0.33	0.36	3.4	94	153	1194	4.51	6.38	300	212	60.4 × 74
	1600	0.28	0.31	4.6	109	178	1524	5.31	7.41	340	244	60.4 × 85
	2000	0.27	0.30	5.7	120	195	1781	5.64	7.72	400	292	60.4 × 102
	3000	0.20	0.23	7.0	150	245	2530	6.45	8.56	525	395	60.4 × 138
	3400	0.20	0.23	8.0	150	245	2175	7.24	9.70	530	395	60.4 × 138
3.0	3000	0.20	0.23	7.0	150	245	2663	7.01	9.48	535	395	60.4 × 138

DT Axial Type, High Temperature Series

- High Power Density
- Rapid charge and discharge
- Ultra-low internal resistance

DH \Rightarrow DT
High Temp.



Item	Characteristics	
Operating temperature range	-40 ~ +85°C	
Rated Voltage	2.5 VDC	
Capacitance tolerance	0% ~ +20%	
Temperature characteristics	Capacitance change	Within $\pm 5\%$ of initial value at +20°C
	Internal resistance change	Within 100% of initial value at +20°C
Endurance (85°C)	Test time	1500 hours
	Capacitance change	Within $\pm 20\%$ of specified value
	Internal resistance change	Less than 100% of specified value
Shelf life (85°C)	After 1500 hours no load test same as endurance	
Life Time at RT ⁽¹⁾	10 years	(1) $ \Delta CI < 20\%$ and $\Delta ESR < 100\%$ of specified value, respectively and $LC <$ specified value
Cycle Life (25°C) ⁽¹⁾⁽²⁾	1,000,000 cycles	(2) Cycle : between rated voltage and half rated voltage under constant current at 25°C

DRAWING

Unit : mm

Threaded Type

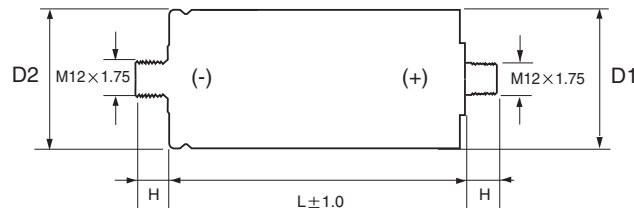
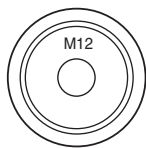

Size(mm)		
H	D1	D2
(± 0.2)	(± 0.2)	(± 0.5)
13.0	$\varnothing 60.4$	$\varnothing 60.7$

Weldable Type

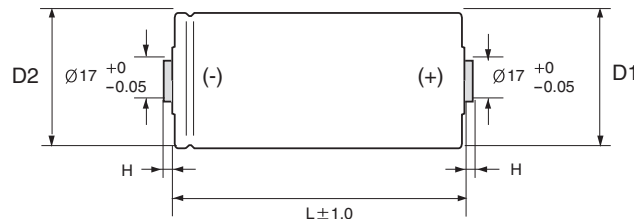
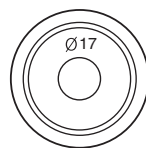

Size(mm)		
H	D1	D2
(± 0.2)	(± 0.2)	(± 0.5)
3.0	$\varnothing 60.4$	$\varnothing 60.7$

CHARACTERISTIC LIST & DIMENSIONS

Rated Voltage	Capacitance (F)	ESR, 1KHz (m Ω)	ESR, DC (m Ω)	LC (72hr) (mA)	Max Continuous Current(A)		Max Peak Current(A)	Specific Energy		Weight (g)	Volume (ml)	Dimension $\varnothing D \times L$ (mm)
					$\Delta T=15^\circ\text{C}$	$\Delta T=40^\circ\text{C}$		(Wh/kg)	(Wh/L)			
2.5	1200	0.30	0.33	2.7	98	159	1074	3.47	4.91	300	212	60.4 \times 74
	1600	0.25	0.28	3.0	115	188	1381	4.08	5.70	340	244	60.4 \times 85
	2000	0.24	0.27	4.0	126	206	1623	4.34	5.94	400	292	60.4 \times 102
	3000	0.20	0.23	5.0	150	245	2219	4.96	6.59	525	395	60.4 \times 138

Green-Cap (ELECTRIC DOUBLE LAYER CAPACITORS)

Upgrade

DB

Snap-in Terminal Type,
Standard Series



- Endurance : 2.5V 70°C 2000 hours, 2.7V 65°C 2000 hours
- The middle size and high capacitance, low resistance
- Charge and discharge efficiency are higher than in batteries

Item	Characteristics	
Operating temperature range	-25 ~ +70°C	-40 ~ +65°C
Rated Voltage	2.5 VDC	2.7 VDC
Capacitance tolerance	-20 ~ +20% or 0% ~ +20% at 20°C	
Temperature characteristics	Capacitance change	Within ±5% of initial value at +20°C
	Internal resistance change	Within 50% of initial value at +20°C
Endurance (2.5V:70°C, 2.7V:65°C)	Test time	2000 hours
	Capacitance change	Within ±30% of specified value
	Internal resistance change	Less than 100% of specified value
Shelf life (2.5V:70°C, 2.7V:65°C)	After 2000 hours no load test same as endurance	
Life Time at RT ⁽¹⁾	10 years	(1) Δ CI < 30% and Δ ESR < 200% of specified value, respectively and LC < specified value
Cycle Life (25°C) ⁽¹⁾⁽²⁾	500,000 cycles	(2) Cycle : between rated voltage and half rated voltage under constant current at 25°C

● DRAWING

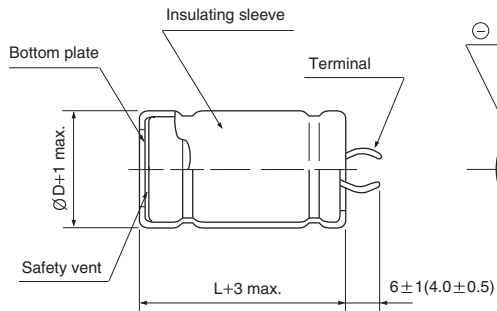

PC Board Mounting Holes

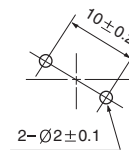

● Terminal

Unit : mm

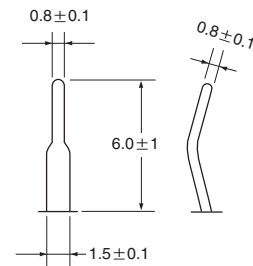

● CHARACTERISTIC LIST & DIMENSIONS

Rated Voltage	Capacitance (F)	ESR, 1KHz (mΩ)	ESR, DC (mΩ)	LC (72hr) (mA)	Max Continuous Current(A)		Max Peak Current(A)	Specific Energy		Weight (g)	Volume (ml)	Dimension ØD×L(mm)
					ΔT=15°C	ΔT=40°C		(Wh/kg)	(Wh/L)			
2.5	100	15.0	35.0	0.25	6.0	10.0	27.8	3.62	5.11	24	17	22 × 45
	200	10.0	20.0	0.50	8.0	13.0	50.0	4.13	5.43	42	32	30 × 45
	300	6.0	15.0	0.75	9.5	15.5	68.2	4.20	5.43	62	48	35 × 50
	360	6.0	12.0	0.90	12.0	19.5	84.6	4.17	5.39	75	58	35 × 60
	400	6.0	10.0	1.00	13.0	21.0	100.0	4.63	5.99	75	58	35 × 60
2.7	100	7.0	9.0	0.27	12.5	20.0	71.1	4.82	5.96	21	17	22 × 45
	120	7.0	9.0	0.32	12.5	20.0	77.9	5.28	6.75	23	18	22 × 47
	200	6.0	8.0	0.54	13.0	21.0	103.8	5.33	6.33	38	32	30 × 45
	300	3.5	5.0	0.81	16.0	26.5	162.0	5.33	6.33	57	48	35 × 50
	325	1.8	2.0	0.88	30.0	50.0	265.9	4.39	5.67	75	58	35 × 60
	360	3.0	3.2	0.97	23.0	38.0	225.8	5.13	6.28	71	58	35 × 60
	400	3.0	3.2	1.08	23.0	38.0	236.8	5.70	6.98	71	58	35 × 60
	400	2.8	3.0	1.08	25.0	40.0	245.5	5.06	6.43	80	63	35 × 65
	450	2.8	3.0	1.22	25.0	40.0	258.5	5.18	6.80	88	67	35 × 70
	500	2.9	3.1	1.35	25.0	40.0	264.7	5.69	7.56	89	67	35 × 70
	600	3.0	3.2	1.62	25.0	40.0	277.4	6.75	9.07	90	67	35 × 70
600	2.8	3.0	1.62	25.0	40.0	289.3	6.08	7.41	100	82	35 × 85	

* Ø35 4 pin type terminal drawing is same see pages.

DK Snap-in Terminal Type, High Temperature Series

- Endurance : 2.7V 85°C 1500 hours
- The middle size and high capacitance, low resistance
- Charge and discharge efficiency are higher than in batteries

DB \Rightarrow **DK**
High Temp.



Item	Characteristics	
Operating temperature range	-40 ~ +85°C	
Rated Voltage	2.7 VDC	
Capacitance tolerance	0% ~ +20%	
Temperature characteristics	Capacitance change	Within $\pm 5\%$ of initial value at +20°C
	Internal resistance change	Within 50% of initial value at +20°C
Endurance (85°C)	Test time	1500 hours
	Capacitance change	Within $\pm 30\%$ of specified value
	Internal resistance change	Less than 100% of specified value
Shelf life (85°C)	After 1500 hours no load test same as endurance	
Life Time at RT ⁽¹⁾	10 years	(1) $I \Delta CI < 30\%$ and $\Delta ESR < 100\%$ of specified value, respectively and $LC <$ specified value
Cycle Life (25°C) ⁽¹⁾⁽²⁾	500,000 cycles	(2) Cycle : between rated voltage and half rated voltage under constant current at 25°C

DRAWING

Unit : mm

PC Board Mounting Holes

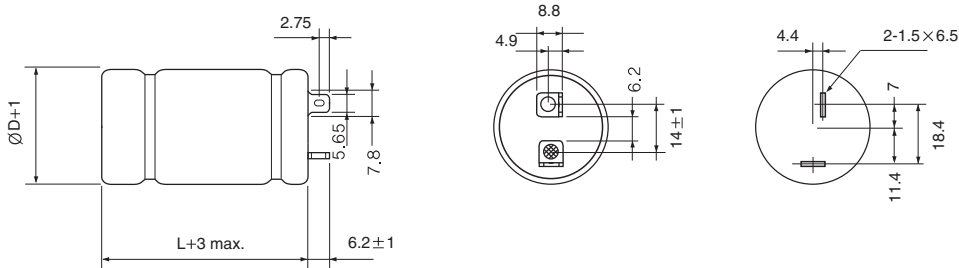

CHARACTERISTIC LIST & DIMENSIONS

Rated Voltage	Capacitance (F)	ESR, 1KHz (mΩ)	ESR, DC (mΩ)	LC (72hr) (mA)	Max Continuous Current(A)		Max Peak Current(A)	Specific Energy		Weight (g)	Volume (ml)	Dimension ØD×L(mm)
					ΔT=15°C	ΔT=40°C		(Wh/kg)	(Wh/L)			
2.7	100	8.0	10.0	0.27	12.0	19.0	68	4.82	5.92	21	17	22 × 45
	200	7.0	9.0	0.54	12.5	20.0	96	5.33	6.37	38	32	30 × 45
	300	3.5	5.0	0.81	16.5	27.0	162	5.33	6.31	57	48	35 × 50
	360	3.2	3.8	0.97	21.5	35.0	205	5.13	6.31	71	58	35 × 60
	400	3.2	3.8	1.08	21.5	35.0	214	5.70	7.02	71	58	35 × 60

Green-Cap (ELECTRIC DOUBLE LAYER CAPACITORS)

DA Snap-in Terminal Type, High Voltage Series



- Endurance : 3.0V 65°C 1500 hours
- The middle size and high capacitance, low resistance
- Charge and discharge efficiency are higher than in batteries

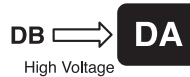

Item	Characteristics	
Operating temperature range	-40 ~ +65°C	
Rated Voltage	3.0 VDC	
Capacitance tolerance	0% ~ +20%	
Temperature characteristics	Capacitance change	Within $\pm 5\%$ of initial value at +20°C
	Internal resistance change	Within 50% of initial value at +20°C
Endurance (65°C)	Test time	1500 hours
	Capacitance change	Within $\pm 30\%$ of specified value
	Internal resistance change	Less than 100% of specified value
Shelf life (65°C)	After 1000 hours no load test same as endurance	
Life Time at RT ⁽¹⁾	10 years	(1) $I\Delta CI < 30\%$ and $\Delta ESR < 100\%$ of specified value, respectively and $LC <$ specified value
Cycle Life (25°C) ⁽¹⁾⁽²⁾	500,000 cycles	(2) Cycle : between rated voltage and half rated voltage under constant current at 25°C

DRAWING

Unit : mm

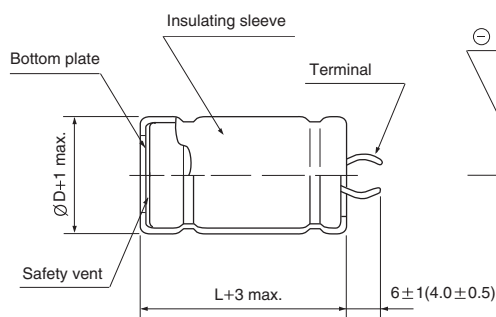

PC Board Mounting Holes

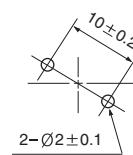

Terminal

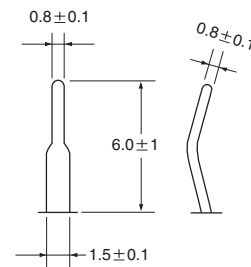

CHARACTERISTIC LIST & DIMENSIONS

Rated Voltage	Capacitance (F)	ESR, 1KHz (mΩ)	ESR, DC (mΩ)	LC (72hr) (mA)	Max Continuous Current(A)		Max Peak Current(A)	Specific Energy		Weight (g)	Volume (ml)	Dimension $\varnothing D \times L$ (mm)
					$\Delta T=15^\circ C$	$\Delta T=40^\circ C$		(Wh/kg)	(Wh/L)			
3.0	100	7.0	9.0	0.30	12.5	20.0	79	5.95	7.31	21	17	22 × 45
	200	6.0	8.0	0.60	13.0	21.0	115	6.58	7.86	38	32	30 × 45
	300	3.5	5.0	0.90	16.0	26.5	180	6.58	7.80	57	48	35 × 50
	360	3.2	3.8	1.08	23.0	38.0	228	6.43	7.80	70	58	35 × 60
	380	3.0	3.2	1.00	25.0	40.0	257	6.60	8.23	72	58	35 × 60
	430	2.8	3.0	1.00	25.0	40.0	282	6.72	8.59	80	63	35 × 65
	480	2.8	3.0	1.00	25.0	40.0	295	6.82	8.91	88	67	35 × 70

DS Radial Type, Standard Series

- Endurance : 2.5V 70°C 1000 hours, 2.7V 65°C 1000 hours, 3.0V 65°C 1000 hours
- The small size and high capacitance, low resistance
- Can be charge and discharge more times than secondary batteries

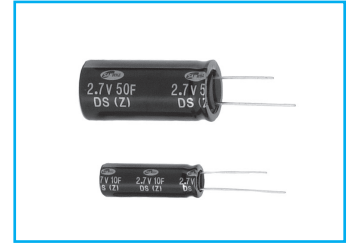

Item	Characteristics		
Operating temperature range	-30 ~ +70°C	-40 ~ +65°C	-40 ~ +65°C
Rated Voltage	2.5 VDC	2.7 VDC	3.0 VDC
Capacitance tolerance	0 ~ +20% at 20°C		
Temperature characteristics	Capacitance change	Within ±5% of initial value at +20°C	
	Internal resistance change	Within 50% of initial value at +20°C	
Endurance (2.5V:70°C, 2.7V:65°C, 3.0V:65°C)	Test time	1000 hours	
	Capacitance change	Within ±30% of specified value	
	Internal resistance change	Less than 100% of specified value	
Shelf life (2.5V:70°C, 2.7V:65°C, 3.0V:65°C)	After 1000 hours no load test same as endurance		
Life Time at RT ⁽¹⁾	10 years	(1) ΔCI < 30% and ΔESR < 100% of specified value, respectively and LC < specified value	
Cycle Life (25°C) ⁽¹⁾⁽²⁾	500,000 cycles	(2) Cycle : between rated voltage and half rated voltage under constant current at 25°C	

DRAWING

Unit : mm

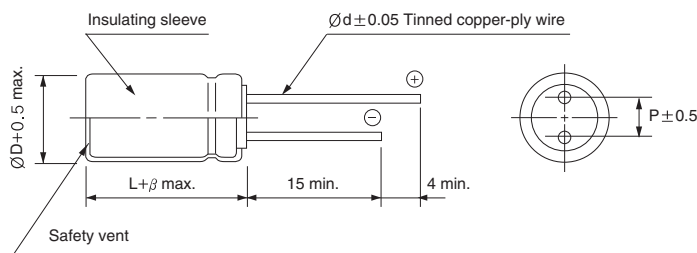

ØD	8	10	16	18
P	3.5	5.0	7.5	7.5
Ød	0.6	0.6	0.8	0.8
β	1.5	2.0		

CHARACTERISTIC LIST & DIMENSIONS

Rated Voltage	Capacitance (F)	ESR, 1KHz (mΩ)	ESR, DC (mΩ)	LC (72hr) (mA Max.)	Specific Energy		Specific Power		Weight (g)	Volume (ml)	Dimension ØD×L(mm)
					(Wh/kg)	(Wh/L)	(W/kg)	(W/L)			
2.5	3	120	260	0.007	1.63	2.60	1,803	2,885	1.6	1.0	8 × 20
	5	70	150	0.010	1.97	2.71	2,273	3,125	2.2	1.6	10 × 20
	10	55	100	0.020	2.48	3.62	2,143	3,125	3.5	2.4	10 × 30
	25	35	65	0.020	2.89	4.34	1,538	2,308	7.5	5.0	16 × 25
	50	20	30	0.120	3.15	4.26	1,812	2,451	13.8	10.2	18 × 40
2.7	3	50	80	0.007	2.17	3.04	7,811	10,935	1.4	1.0	8 × 20
	5	45	60	0.010	2.41	3.16	6,943	9,113	2.1	1.6	10 × 20
	10	25	45	0.023	3.49	4.22	6,703	8,100	2.9	2.4	10 × 30
	15	20	40	0.030	3.38	4.90	4,860	7,055	4.5	3.1	12.5 × 25
	25	15	25	0.045	3.78	5.06	5,223	6,998	6.7	5.0	16 × 25
	33	11	20	0.060	3.34	4.13	4,374	5,400	10.0	8.1	18 × 32
	50	9	15	0.075	4.40	4.96	5,071	5,718	11.5	10.2	18 × 40
	100	8	13	0.180	4.82	5.92	3,204	3,935	21.0	17.1	22 × 45
3.0	3	60	105	0.010	2.34	3.75	6,429	10,286	1.6	1.0	8 × 20
	5	50	90	0.015	2.84	3.91	5,455	7,500	2.2	1.6	10 × 20
	10	30	45	0.030	3.57	5.21	6,857	10,000	3.5	2.4	10 × 30
	15	25	40	0.050	4.17	6.05	6,000	8,710	4.5	3.1	12.5 × 25
	25	20	30	0.070	4.17	6.25	4,800	7,200	7.5	5.0	16 × 25
	50	10	20	0.150	4.53	6.13	3,913	5,294	13.8	10.2	18 × 40

Green-Cap (ELECTRIC DOUBLE LAYER CAPACITORS)

DJ Radial Type, High Temperature Series

- Endurance : 2.5V 85°C 1000 hours
- The small size and high capacitance, low resistance
- Can be charge and discharge more times than secondary batteries

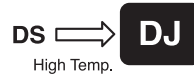

Item	Characteristics	
Operating temperature range	-40 ~ +85°C	
Rated Voltage	2.5 VDC	
Capacitance tolerance	0% ~ +20% at 20°C	
Temperature characteristics	Capacitance change	Within $\pm 5\%$ of initial value at +20°C
	Internal resistance change	Within 50% of initial value at +20°C
Endurance (85°C)	Test time	1000 hours
	Capacitance change	Within $\pm 30\%$ of specified value
	Internal resistance change	Less than 100% of specified value
Shelf life (85°C)	After 1000 hours no load test same as endurance	
Life Time at RT ⁽¹⁾	10 years	(1) $I \Delta CI < 30\%$ and $\Delta ESR < 100\%$ of specified value, respectively and $LC <$ specified value
Cycle Life (25°C) ⁽¹⁾⁽²⁾	500,000 cycles	(2) Cycle : between rated voltage and half rated voltage under constant current at 25°C

● DRAWING

Unit : mm

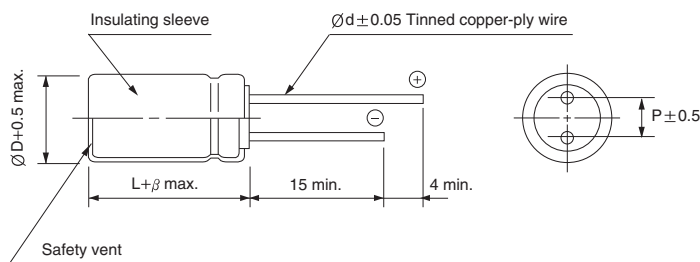

ØD	8	10	16	18
P	3.5	5.0	7.5	7.5
Ød	0.6	0.6	0.8	0.8
β	1.5	2.0		

● CHARACTERISTIC LIST & DIMENSIONS

Rated Voltage	Capacitance (F)	ESR, 1KHz (mΩ)	ESR, DC (mΩ)	LC (72hr) (mA Max.)	Specific Energy		Specific Power		Weight (g)	Volume (ml)	Dimension ØD×L(mm)
					(Wh/kg)	(Wh/L)	(W/kg)	(W/L)			
2.5	3	60	105	0.008	1.63	2.60	4,464	7,143	1.6	1.0	8 × 20
	5	50	90	0.013	1.97	2.71	3,788	5,208	2.2	1.6	10 × 20
	10	30	45	0.025	2.48	3.62	4,762	6,944	3.5	2.4	10 × 30
	15	25	40	0.050	2.89	4.20	4,167	6,048	4.5	3.1	12.5 × 25
	25	20	30	0.063	2.89	4.34	3,333	5,000	7.5	5.0	16 × 25
	50	10	20	0.150	3.15	4.26	2,717	3,676	13.8	10.2	18 × 40